

QUBE

66 (3,9 m²)

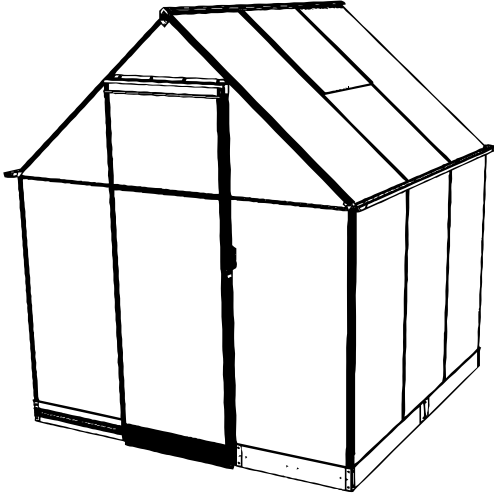

68 (5,1 m²)

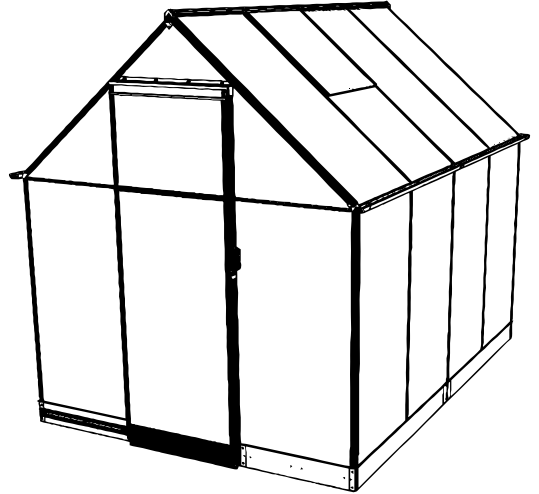

610 (6,4 m²)

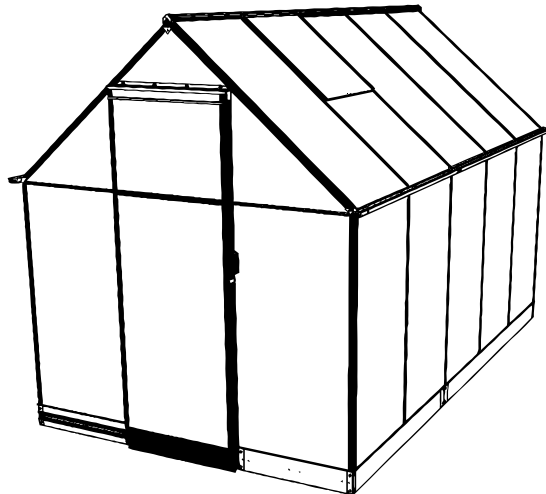

GB: DEAR CUSTOMER,

Congratulations on purchasing your new greenhouse. Please take note it is important that you follow these assembly instructions step-by-step.

SOME SAFETY PRECAUTIONS

- Assembly must only be carried out in dry and calm weather.
- Always wear work gloves when installing the glazing. Greenhouse glass has sharp edges, especially if it breaks.
- Assistants and especially children must be warned that broken glass is dangerous. Pick up all broken glass at once and remove it with care.
- Any ladders that are used must be placed on a level surface.

WATER & CONDENSATION

Please note that your greenhouse is not like a conservatory for example, and that you should therefore be aware that the greenhouse may leak during or after precipitation and that condensation will occur on the inside of the greenhouse. Good ventilation will help to prevent condensation.

MAINTENANCE

- Grease the doors (hinges and locks).
- Keep the gutters free from leaves, etc.
- Adjust the windows as necessary.
- Replace any broken glass.
- Clean the greenhouse with disinfectant before and after the growing season.

WINTER PROTECTION

If you anticipate snow during the winter, we recommend the following winter precautions:

- Support the apex of the roof in the middle.
- Remove any deep snow from the roof.
- Take precautions to prevent snow falling from a tree or roof, for example.
- Remove the cylinders for the automatic window openers, if fitted (optional extras).
- Secure the door(s) and window(s) to prevent wind damage to the greenhouse.

INSURANCE

Please note that not all insurance companies cover greenhouses automatically. Contact your insurance company to ensure your greenhouse is covered.

GUARANTEE

Halls greenhouses are covered by a 10-year guarantee, which covers the frame and ancillary parts only. The guarantee does not cover polycarbonate, glass, transport, assembly, freight, etc. Halls greenhouses are covered by a two-year warranty on painted parts, where fitted. Note that marks on the paint may occur due to suspension of the profiles. The guarantee will be void if the greenhouse is not assembled in accordance with these instructions.

COMPLAINTS

All our greenhouses are built to the highest quality standards. However, should you experience any problems, please contact your dealer at once. When describing the defect, please state the greenhouse model and part number.

Congratulations on your new greenhouse, which we hope will bring you a lot of pleasure for many years to come.

Yours sincerely,

Juliana Group

DK: KÆRE KUNDE,

Tillykke med købet af dit nye drivhus. Montagen af dit nye drivhus kræver, at du følger denne vejledning trin for trin. Læs eventuelt vejledningen igennem før montagen påbegyndes.

RÅD OM SIKKERHED

- Montage bør kun foregå i tørt og stille vejr
- Ved glasmontage skal der bruges handsker. Glasset kan have skarpe kanter.
- Medhjælpere og specielt børn skal gøres opmærksomme på, at knust glas er et faremoment. Saml straks knust glas op og bortskaf det med omtanke
- Når en stige bruges, bør den altid placeres forsvarligt og på et plant underlag.
- Det er nødvendigt at have en medhjælper til samlingen af dit drivhus.

VAND OG KONDENS

Vi gør opmærksom på, at dit drivhus ikke er at sammenligne med f.eks. en udestue, og vi gør derfor opmærksom på, at der i forbindelse med nedbør kan være visse utætheder i huset, og at kondens ligeledes vil fremtræde på indersiden af huset. Sørg for god udluftning for at undgå kondens.

VEDLIGEHOLDELSE

- Smøre døre (hængsler og lås).
- Rengøre tagrende for blade o. lign.
- Justering af vinduer.
- Udskifte ituslået glas.
- Rengøre huset med desinficerende middel før og efter vækstsæson.

VINTERSIKRING

I områder, hvor der kan forekomme sne, anbefaler vi følgende vintersikring:

- Understøttelse af tagryggen midt i huset.
- Større mængder sne på taget bør skrubes ned.
- Tag forholdsregler mod nedstyrtende snemasser f.eks. fra træ eller hustag.
- Fastgør dør og vinduer så vinden ikke kan få fat og lave skade på huset.

FORSIKRING

Vær opmærksom på, at ikke alle forsikringselskaber automatisk dækker skader på drivhuse. Kontakt dit forsikringselskab for at sikre korrekt dækning.

GARANTI

Der ydes 10 års garanti, som dækker ombygning eller reparation af defekte dele. Garantien omfatter ikke polycarbonat, glas, transport, montage, fragt m.v. Der ydes 2 års garanti på eventuel lakering. Bemærk at der kan forekomme mærker i malingen, som stammer fra ophængning af profiler. Garantien bortfalder, hvis drivhuset ikke er monteret i overensstemmelse med denne vejledning.

REKLAMATIONER

Vi har strenge kvalitetskrav for at sikre dig et fejlfrit produkt. Skulle der alligevel være fejl eller mangler, så kontakt straks din forhandler. Husk at specificere manglen ved at oplyse drivhusmodel og partnummer.

Vi ønsker et stort tillykke med det nye drivhus, som vi håber vil bringe stor glæde i mange år fremover.

Med venlig hilsen

Juliana Group

G: SEHR GEEHRTER KUNDE!

Herzlichen Glückwunsch zum Kauf Ihres neuen Gewächshauses. Bitte beachten Sie, dass es wichtig ist, dass Sie diese Montageanleitung Schritt für Schritt folgen.

SICHERHEITSHINWEISE

- Die Montage darf nur bei trockenem und windstillem Wetter erfolgen.
- Tragen Sie beim Einsetzen der Glasscheiben unbedingt Arbeitshandschuhe. Gewächshausglas hat scharfe Kanten, besonders wenn es zerbricht.
- Helfer und besonders Kinder müssen auf das Risiko von Glasbruch hingewiesen werden. Glasbruch muss sofort aufgesammelt und sorgfältig entsorgt werden.
- Stellen Sie eine evtl. notwendige Leiter auf eine ebene Fläche.

WASSER UND KONDENSAT

Wir weisen darauf hin, dass Ihr Gewächshaus nicht mit einem Wintergarten zu vergleichen ist – bei Niederschlägen können Undichtigkeiten auftreten; auch Kondensatbildung an den Hausinnenseiten ist möglich. Kondenswasser können Sie durch gute Lüftung vermeiden.

PFLEGE

- Tür schmieren (Scharniere und Schloß)
- Dachrinne von Blättern u. ä. reinigen
- Fenster justieren
- Gebrochenes Glas austauschen
- Haus vor und nach der Anbausaison mit Desinfektionsmittel reinigen

WINTERSICHERUNG

In Schneegebieten empfehlen wir folgende Wintersicherung:

- Den Dachrücken mitten im Haus abstützen
- Bei starker Schneelast das Dach freimachen
- Sichern Sie das Haus vor evtl. abstürzenden Schneemassen von Bäumen u.a.
- Zylinder zur automatischen Fensteröffnung (sofern vorhanden, Extrazubehör) demontieren
- Zum Schutz des Hauses Tür(en) und Fenster sichern, damit der Wind sie nicht hin- und herschlagen kann

VERSICHERUNG

Wir weisen darauf hin, dass nicht alle Versicherungen automatisch Gewächshäuser abdecken. Fragen Sie bei Ihrer Versicherung nach.

GARANTIE

Es werden 10 Jahre Garantie geleistet, die Austausch oder Reparatur defekter Teile deckt. PC-Stegplatten, Glas, Transport, Montage, Fracht und dgl. sind nicht in der Garantie enthalten. Auf eventuelle Lackierungen werden zwei Jahre Garantie geleistet. Beachten Sie, dass Kratzer im Lack durch die Aufhängung der Profile möglich sind.

Die Garantie entfällt, wenn das Haus nicht gemäß dieser Montageanleitung montiert wurde.

REKLAMATIONEN

Wir haben strenge Qualitätsansprüche, um Ihnen ein fehlerfreies Produkt zu sichern. Sollten trotzdem Fehler oder Mängel auftreten, wenden Sie sich umgehend an Ihren Händler. Beschreiben Sie genau den Mangel und geben Sie Gewächshausmodell und Teilenummer.

Wir gratulieren Ihnen zu Ihrem neuen Gewächshaus, das Ihnen hoffentlich viele Jahre lang Freude machen wird.

Mit freundlichem Gruß,

Juliana Group

S: BÄSTA KUND!

Vi gratulerar till ditt nya växthus. Vänligen notera att det är viktigt att du följer dessa steg för steg monteringsanvisning.

SÄKERHETSÅD

- Montering bör endast ske i torrt och lugnt väder.
- Använd alltid handskar vid glasmontering. Växthusglas har vassa kanter, särskilt när det går sönder.
- Medhjälpare och särskilt barn ska göras uppmärksamma på att krossat glas är en fara. Samla upp allt krossat glas och kasta det direkt.
- Om det behövs en stege ska den placeras på plant underlag.

VATTEN OCH KONDENS

Vi vill göra dig uppmärksam på att drivhuset inte ska jämföras med t.ex. ett uthus, och vill därför påpeka att det i samband med nederbörd kan finnas vissa otätheter i huset och att kondens kan framträda på insidan av huset. Se till att ventilationen är god för att undvika kondens.

UNDERHÅLL

- Smörj dörrar (gångjärn och lås).
- Rengör takrännan från blad och liknande.
- Justera fönster.
- Byt ut trasigt glas.
- Rengör huset med desinficeringsmedel före och efter växtsäsongen.

VINTERSÄKRING

I områden där snöfall förekommer rekommenderar vi följande vintersäkring.

- Staga uppnockprofilen med en stolpe mitt i huset.
- Ta bort större mängder snö från taket.
- Se till att skyddsåtgärder finns mot nedfallande snö, t.ex. från träd eller hustak.
- Demontera cylindern till den automatiska fönsteröppnaren (extrautrustning).
- Lås fast dörrar och fönster så att vinden inte kan skada huset.

FÖRSÄKRING

Var uppmärksam på att inte alla försäkringsbolag automatiskt försäkrar växthus. Kontakta ditt försäkringsbolag och teckna försäkring.

GARANTI

Växthuset har 10 års garanti som täcker byte eller reparation av defekta delar. Garantin täcker inte polykarbonat, glas, transport, montering, frakt m.m. Det är 2 års garanti vid eventuell lackering. Tänk på att det kan förekomma märken i lackeringen som kommer från uppsättningen av profilerna.

Garantin gäller inte om växthuset inte monteras enligt dessa anvisningar.

REKLAMATIONER

Vi har höga kvalitetskrav för att säkerställa en felfri produkt. Om du ändå hittar fel eller om det saknas delar ska du kontakta din återförsäljare på en gång.

Kom ihåg att specificera felet genom att lämna information om växthusmodell och artikelnummer

Stort grattis till det nya växthuset. Vi hoppas att det kommer att innebära mycket glädje i många år framöver.

Med vänlig hälsning

Juliana Group

F: CHER CLIENT,

Nous vous félicitons d'avoir acheté de la serre. Veuillez prendre note qu'il est important que vous suivez ces instructions d'assemblage étape par étape.

CONSEILS DE SECURITE

- Le montage doit uniquement se faire par un temps sec et calme.
- Toujours utiliser des gants de protection en manipulant du verre. Le verre de serres a des bords très coupants surtout s'il casse.
- Quand vous êtes assisté, surtout par des enfants, ne pas oublier de prévenir du danger. En cas de bris de verre, le ramasser et le jeter soigneusement.
- Si vous utilisez des échelles prenez soin de les placer sur une surface plane.

EAU ET CONDENSATION

Nous attirons votre attention sur le fait que votre serre ne peut être comparée avec une véranda, par ex., et qu'il peut, par conséquent, en cas de pluie ou de neige, y avoir quelques fuites dans la serre. De même, la condensation peut se former à l'intérieur de la serre. Veiller à bien ventiler pour éviter la condensation.

ENTRETIEN

- Graisser les portes (charnières et fermeture)
- Nettoyer les gouttières de feuilles, etc.
- Ajuster les fenêtres.
- Changer le vitrage cassé
- Nettoyer la serre avec un désinfectant avant et après la saison.

PRECAUTIONS D'HIVER

Dans les régions avec risques de neige, nous vous recommandons les précautions suivantes :

- Soutenir le toit au milieu
- Retirer les quantités de neige importantes
- Prévoir des chutes de neige provenant des arbres ou des toits voisins
- Démontez d'éventuels cylindres des ouvre-toit automatiques (en option)
- Fixer les portes et les fenêtres pour les protéger contre le vent.

ASSURANCE

Contactez votre compagnie d'assurance pour vérifier dans quelle mesure votre assurance couvre votre serre.

GARANTIE

Halls vous accorde 10 ans de garantie qui couvre la réparation ou le remplacement des pièces défectueuses. La garantie ne couvre pas le polycarbonate, le vitrage, le transport, le montage, etc. Vous bénéficiez de 2 ans de garantie sur la laque événementielle. Veuillez noter que des marques, provenant de la suspension des profils lors du vernissage, peuvent exister. Cette garantie devient caduque si la serre n'est pas montée conformément aux instructions du présent manuel.

RECLAMATIONS

Nous soumettons nos serres à des contrôles très sévères pour vous garantir un produit sans défaut. Si toutefois vous trouvez des défaillances ou des défauts, nous vous prions de vous adresser immédiatement à votre revendeur tout en vous référant au modèle de serre et numéro de pièce.

Nous vous félicitons pour l'acquisition de votre nouvelle serre qui, nous l'espérons, vous apportera un grand plaisir pendant de nombreuses années à venir.

Meilleurs sentiments.

Juliana Group

NL: BESTE KLANT,

Gefeliciteerd met uw aankoop van uw nieuwe serre. Let op dat het is belangrijk dat u deze stap voor stap montage-instructies volgen.instructions.

VOORZORGSMAATREGELEN

- De montage mag alleen uitgevoerd worden in droog weer met weinig wind.
- Gebruik altijd handschoenen bij het monteren van glas. Het glas voor de kas heeft scherpe kanten, vooral als het stukgaat.
- Hulpen, en met name kinderen, moeten erop gewezen worden dat gebroken glas gevaarlijk kan zijn. Ruim gebroken glas meteen op en verpak het goed voordat u het weggooit.
- Als u een ladder gebruikt, moet deze op een egale ondergrond staan.

WATER EN CONDENS

Wij wijzen erop dat uw kas niet kan worden vergeleken met bijv. een serre en dat de kas bij neerslag niet helemaal afgedicht is, zodat er in de kas condens kan ontstaan. Lucht goed om condens te voorkomen.

ONDERHOUD

- Smeer de deuren (scharnieren en slot).
- Verwijder bladeren e.d. uit de dakgoten.
- Stel de ramen bij.
- Vervang kapot glas.
- Reinig de kas voor en na het seizoen met een ontsmettingsmiddel.

WINTERVOORZORG

In gebieden waar sneeuw kan vallen, raden wij het volgende aan:

- Stut de dakrug midden in de kas.
- Verwijder grote hoeveelheden sneeuw van het dak.
- Neem voorzorgsmaatregelen tegen neerstortende sneeuw van bomen of huisdaken.
- Demonteer cilinders van eventuele automatische raamopeners (optioneel).
- Zet deur(en) en raam/ramen vast, zodat de wind ze niet kan beschadigen.

VERZEKERING

Denk eraan dat niet alle verzekeringsmaatschappijen kassen automatisch verzekeren. Vraag uw verzekeringsmaatschappij of uw kas gedekt is.

GARANTIE

Er wordt 10 jaar garantie verleend, die omruiling of reparatie van defecte delen dekt. De garantie omvat niet: polycarbonaat, glas, transport, montage, vracht e.d.

Er wordt 2 jaar garantie verleend op evt. lakken. Let op dat er merken in de verf kunnen voorkomen, die ontstaan zijn door het ophangen van profielen. De garantie vervalt als de kas niet in overeenstemming met deze handleiding gemonteerd is.

RECLAMATIES

Wij voldoen aan strenge kwaliteitseisen om u een foutloos product te garanderen. Mochten er toch fouten of gebreken zijn, dan dient u meteen contact op te nemen met uw handelaar. Denk eraan het gebrek te specificeren door het vermelden van het model en onderdeelnummer.

Wij feliciteren u van harte met uw nieuwe kas en wij hopen, dat u er jarenlang veel plezier van zult hebben.

Met vriendelijke groet,

Juliana Group

E: ESTIMADO CLIENTE,

Felicidades por comprar su nuevo Invernadero. Tenga en cuenta que es importante que siga estas Instrucciones paso a paso.

PRECAUCIONES DE SEGURIDAD

- El montaje solamente debe realizarse con un clima seco y sin viento.
- Siempre se deben usar guantes para instalar los cristales. Los cristales para Invernaderos tienen bordes afilados, especialmente si se rompen.
- Se debe informar a los ayudantes y especialmente a los niños de que un cristal roto es peligroso. Se deben recoger inmediatamente los cristales rotos y eliminarlos con cuidado.
- Si utiliza una escalera, esta debe colocarse sobre una superficie plana.

AGUA Y CONDENSACIÓN

Recuerde que su Invernadero no es hermético, que podría detectar fugas durante o después de unas precipitaciones y que se producirá condensación dentro del mismo. Una buena ventilación ayudará a evitar la condensación.

MANTENIMIENTO

- Engrase las puertas (bisagras y cerradura).
- Limpie las canaletas para evitar la presencia de hojas, etc.
- Ajuste las ventanas según sea necesario.
- Sustituya los cristales rotos.
- Limpie el Invernadero con un agente desinfectante antes y después de la temporada de cultivo.

PROTECCIÓN EN INVIERNO

En las zonas donde puede haber nevadas, se recomienda la siguiente protección durante el invierno:

- Apoye el vértice de unión del tejado por el centro.
- Elimine cualquier acumulación grande de nieve del tejado.
- Debe tomar medidas contra la caída de nieve, por ejemplo desde árboles o tejados de edificios.
- Desmonte los cilindros de eventuales abridores de ventanas automáticos (complemento extra).
- Fije las puerta(s) y ventana(s) de modo que el viento no pueda dañar el Invernadero.

SEGUROS

Tenga en cuenta que no todas las compañías de seguros cubren automáticamente los Invernaderos. Póngase en contacto con su compañía de seguros para asegurarse de que el seguro lo cubre.

GARANTÍA

Los Invernaderos Halls están cubiertos por una garantía de 10 meses que incluye la sustitución o reparación de componentes defectuosos. La garantía no cubre el polycarbonato, cristal, transporte, montaje, carga, etc. Los Invernaderos Juliana tienen una garantía de dos años sobre las piezas pintadas, si las hubiera. Recuerde que puede haber marcas en la pintura que provienen del colgado de los perfiles. La garantía no será válida en caso de no montar el Invernadero según estas Instrucciones.

RECLAMACIONES

Todos nuestros Invernaderos se han construido siguiendo los más altos estándares de calidad. No obstante, si tuviera algún problema, no dude en ponerse en contacto con su distribuidor inmediatamente. Recuerde especificar el defecto informando del modelo de Invernadero y número de parte.

Enhorabuena por la adquisición de su nuevo Invernadero, del que esperamos que disfrute durante muchos años.

Atentamente,

Juliana Group

EST: LUGUPEETUD KLIENT,

Palju õnne uue kasvuhoone puhul!

Kogu juhend koos jooniste ja videotega on üleval meie kodulehel iga mudeli juures.

Kodulehelt leiате alamjaotuse "Videod ja juhendid" alt ka terve rea videoid, mis näitavad kasvuhoone paigalduse erinevaid etappe.

Kasvuhoone monteerimiseks jälgige samm-sammult juhendit.

TURVALISUS:

- paigaldage kasvuhoonet ainult kuiva ja tuulevaise ilmaga;
- klaaside käsitsemisel kasutage töökindaid. Palun hoidke lapsed ja koduloomad klaasimistöde juurest eemal. Klaaside ääred on teravad. Kui juhtub, et klaas puruneb, korjake kohe killud kokku ning utiliseerige klaasijäätid. Soovitav on klaaside ja vedruklambrite käsitsemisel kanda ka kaitseprille;
- redelid asetage tasasele pinnale;
- kasvuhoone montaaž sujub paremini vähemalt kahe inimese koostöös.

HOOLDUS:

- õlitage uksehingi ja lukku;
- puhastage aeg-ajalt katuserenne;
- kontrollige, kas aknad liiguvad vabalt;
- vahetage välja katkised klaasid;
- puhastage kasvuhoonet nii kevadel kui sügisel, kasutage desinfitseerivaid vahendeid (Juliana kasvuhoone biopesemivahendeid).

TALVEL:

- lumerohtetel talvedel toetage seestpoolt kasvuhoone keskelt katus ning eemaldage suur lumi;
- vaadake, et teiste hoonete katustelt või suurte puude pealt ei kukuks suurt hulka lund kasvuhoonele;
- kui olete paigaldanud akendele automaatsed aknaavajad, kruvige maha automaatsete aknaavajate silindrid ning hoiustage neid toas;
- kinnitage automaatsed aknaavajad pakendis kaasas olnud punase takjapaelaga, et
- aknaluugid talvel paigal püsiks;
- veenduge, et tuul ei pääseks uksi ja aknaid liigutama.

VESI JA KONDENSAAT:

- kasvuhoone ei ole võrreldav tavaliste ehitistega, ikka võib kuskilt vett läbi tilkuda ja sisepindadele kondensaati koguneda;
- kondensaadi teket saab vältida hoolika tuulutamisega.

KINDLUSTUS:

kodukindlustust tehes soovitame kindlustada ka kasvuhoone.

GARANTII:

- Halls kasvuhoonte karkassi detailide tootmisvigadele kehtib 10-aastane garantii;
- garantii ei laiene klaasile, polükarbonaatplaatidele, transpordile, paigaldusele;
- värvitud osadele kehtib 2-aastane garantii, värvitud osadel võib esineda väikseid kriimustusi, mis on tekkinud detailide riputamisel pulbervärvimise käigus;
- garantii ei kehti, kui kasvuhoone ei ole paigaldatud vastavalt juhistele.

KAEBUSED:

Halls tehasel on kõrged kvaliteedistandardid. Kui siiski ilmuvad puudused, pöörduge kohe oma kasvuhoone müüja poole. Kirjeldage täpselt, milles viga seisneb, täpsustage kasvuhoone tüüp ning vigase detaili number.

Loodame, et Halls kasvuhoone pakub Teile pikkadeks aastateks rõõmu!

Lugupidamisega

Anu Poed OÜ

Juliana Drivhuse A/S

www.kasvuhooned.ee

www.juliana.ee

FIN: ARVOISA ASIAKAS,

Onnittelut uuden kasvihuoneesi hankinnasta. Huomaa, että noudatat näitä asennusohjeita vaihteittain.

TURVALLISUUSOHJEITA

- Kasvihuoneen pystytys tulee suorittaa kuivalla ja tyyneellä säällä.
- Käytä aina käsineitä laseja asentaessasi. Kasvihuoneelassissa on terävät reunat, erityisesti jos se särkyi.
- Varoita avustajia ja lapsia siitä, että lasinsirut voivat olla vaarallisia. Kerää lasinsirut talteen ja toimita ne turvallisesti lasinkeräyspisteeseen.
- Aseta tikkaat tasaiselle alustalle.

VESI JA KONDENSIVESI

Huomaa, että kasvihuoneettasi ei voi verrata esim. katettuun terassiin. Sateella vettä saattaa vuotaa kasvihuoneen sisälle ja kosteutta tiivistyy myös kasvihuoneen sisäpinnoille. Huolehdi siksi hyvästä tuuletuksesta, jotta välttyt kondenssivedeltä.

YLLÄPITO

- Voitele ovet (saranat ja lukot).
- Pidä vesikourut irti lehdistä jne.
- Säädä ikkunat tarpeen mukaan.
- Vaihda rikkoutunut lasi.
- Puhdista kasvihuone desinfiointiaineella ennen kasvukautta ja sen jälkeen.

TALVISUOJA

Jos odotat lunta talven aikana, suosittelemme seuraavia talvia koskevia varotoimia:

- Tukea katon kärkiä keskellä.
- Poista syvä lumi katolta.
- Noudata varotoimia, jotta esimerkiksi lumi ei pääse puusta tai katosta.
- Poista automaattisten ikkunoiden avaimien sylinterit, jos ne on asennettu (lisävarusteet).
- Kiinnitä luukku (t) ja ikkuna (t), jotta tuuli ei vahingoitu kasvihuoneeseen.

VAKUUTUS

Huomaa, että kaikki vakuutukset eivät kata automaattisesti kasvihuoneita. Ota yhteyttä vakuutusyhtiösi tarkistaaksesi vakuutus-turvasi.

TAKUU

Myönämme kasvihuoneelle 10 vuoden takuun, joka kattaa viallisten osien vaihdon tai korjauksen. Takuu ei koske polykarbonaattilevyjä, laseja, kuljetuskustannuksia, asennustyötä, rahtia ym. Maalipinnoille myönnetään 2 vuoden takuu. Huomaa, että maalipinnoissa voi olla jälkiä, jotka syntyivät profiilien asennuksen yhteydessä. Takuu raukeaa, mikäli kasvihuonetta ei ole asennettu tämän ohjeen mukaisesti.

REKLAMAATIOT

Meillä on tiukat laatuvaatimukset, joilla varmistamme, että sinä saat virheettömän tuotteen. Jos huomaat kasvihuoneessasi vikoja tai puutteita, ota heti yhteys jälleenmyyjääsi. Muista määrittää kasvihuonemallin ja osanumeron puute.

Toivotamme sinulle onnea uuden kasvihuoneesi johdosta ja toivomme, että siitä on sinulle iloa moneksi vuodeksi.

Ystävällisin terveisin,

Juliana Group

PL: DROGI KLIENCIE,

Gratulujemy zakupu nowej szklarni. Proszę zwrócić uwagę, że to ważne, postępuj zgodnie z instrukcją montażu krok po kroku.

NIEKTÓRE ZASADY BEZPIECZEŃSTWA

- Montaż należy przeprowadzać wyłącznie przy suchej i spokojnej pogodzie.
- Zawsze nosić rękawice robocze przy instalacji szyby, szkło ma ostre krawędzie, zwłaszcza, gdy skruszy się.
- Asystentów, a szczególnie dzieci muszą być powiadomieni, że rozbite szkło jest niebezpieczne. Zebrać wszystkie tłuczone szkła i usunąć je bezpiecznie.
- Wszystkie drabiny, które są używane, muszą być umieszczone na płaskiej powierzchni.

WODA I KONDENSACJE

Należy pamiętać, że szklarnia nie jest na przykład konserwatorium i dlatego należy mieć świadomość, że szklarnia może przeciekać w trakcie opadów lub po nich, a także wskutek kondensacji może pojawić się woda wewnątrz szklarni. Dobra wentylacja pomoże zapobiec kondensacji.

KONSERWACJA

- Nasmaruj drzwi (zawiasy i zamki).
- Utrzymuj rynny wolne od liści itp.
- Dostosuj okna w razie potrzeby.
- Wymień potłuczone szkło.
- Czyszczenie szklarni środkiem dezynfekującym przed i po sezonie wegetacyjnym.

OCHRONA PRZED ZIMĄ

Jeśli spodziewasz się śniegu w zimie, zalecamy następujące środki ostrożności zimowe:

- Podeprzyj wierzchołek dachu pośrodku.
- Usuń głęboki śnieg z dachu.
- Podejmij środki ostrożności, aby na przykład zapobiec spadaniu śniegu z drzewa lub dachu.
- Zdejmij cylindry do automatycznych otwieraczy, jeśli są zamontowane (opcjonalne dodatki).
- Zabezpiecz drzwi i okna, aby zapobiec uszkodzeniom spowodowanym przez wiatr w szklarni.

UBEZPIECZENIE

Należy pamiętać, że nie wszystkie firmy ubezpieczeniowe automatycznie zajmują się szklarniami. Skontaktuj się z firmą ubezpieczeniową, aby upewnić się, że szklarnia jest objęta ubezpieczeniem.

GWARANCJA

Szklarnie Halls objęte są 10-letnią gwarancją obejmującą wymianę lub naprawę wadliwych części. Gwarancja nie obejmuje poliwęglanu, szkła, transportu, montażu, frachtu itp. Halls szklarnie objęte są dwuletnią gwarancją na lakierowane części, jeżeli są zamontowane. Należy zwrócić uwagę, że na powłóce mogą pojawić się ślady na lakierze.

Gwarancja zostanie nieważniona, jeśli szklarnia nie zostanie zmontowana zgodnie z tymi instrukcjami.

REKLAMACJE

Wszystkie nasze szklarnie są zbudowane zgodnie z najwyższymi standardami jakości. Jeśli jednak wystąpią jakiegokolwiek problemy, należy natychmiast skontaktować się ze sprzedawcą. Opisując wady, proszę podać model szklarni i numer części.

Gratulujemy nowej szklarni, która, mamy nadzieję, przyniesie Ci wiele przyjemności na wiele lat.

Pozdrawiam serdecznie,

Juliana Group

N: KJÆRE KUNDE,

Vi gratulerer med din nye drivhus. Behage ta note det er viktig at du følger instruksjonene montering trinnvis.

NOEN SIKKERHETSREGLER

- Montering må bare utføres i tørt og rolig vær.
- Bruk alltid vernehansker når installere Vinduer, drivhus glass har skarpe kanter, spesielt hvis det bryter.
- Assistenten og særlig barn må bli advart at knust glass er farlig. Plukke opp alle knust glass på en gang og ta den med omhu.
- Stiger som brukes må plasseres på en plan overflate.

VANN OG KONDENS

Merk at drivhuset er ikke som en vinterhage, for eksempel, og at du bør derfor være klar over at drivhuset kan lekke under eller etter nedbør og at det vil oppstå kondens på innsiden av drivhuset.

God ventilasjon vil bidra til å hindre kondensering.

VEDLIKEHOLD

- Smør dørene (hengsler og låser).
- Hold rennene fri fra blader, etc.
- Juster vinduene etter behov.
- Bytt ut et ødelagt glass.
- Rengjør drivhuset med desinfeksjonsmiddel før og etter vekstsesongen.

VINTER BESKYTTELSE

Hvis du forventer snø om vinteren, anbefaler vi følgende vinterregler:

- Støtter toppens topp i midten.
- Fjern eventuell dyp snø fra taket.
- Forholdsregler for å hindre snø som faller fra et tre eller et tak.
- Fjern sylindrene til de automatiske vindusåpnene, hvis montert (tilleggsutstyr).
- Sikre dørene og vinduene for å hindre vindskader på drivhuset.

FORSIKRING

Vær oppmerksom på at ikke alle forsikringsselskaper dekker veksthus automatisk. Kontakte ditt forsikringsselskap for å sikre drivhuset er dekket.

GARANTI

Hallene drivhusene er dekket av en 10 års garanti som dekker utskifting eller reparasjon av defekte deler. Garantien dekker ikke polykarbonat, glass, transport, montering, frakt, etc. Hallene drivhusene er dekket av en to-års garanti på malt deler, hvor montert. Merk at merkene på malingen kan oppstå på grunn av suspensjon av profilene.

Garantien blir ugyldig hvis drivhuset ikke er montert i samsvar med disse instruksene.

KLAGER

Alle våre drivhusene er bygget til høyeste kvalitet. Imidlertid bør du oppleve problemer, vennligst kontakt din forhandler samtidig. Når de beskriver feilen, vennligst oppgi drivhuset modell og delenummer.

Gratulerer med din nye drivhus, som vi håper vil gi deg mye glede i mange år framover.

Din vennlig hilsen,

Juliana Group

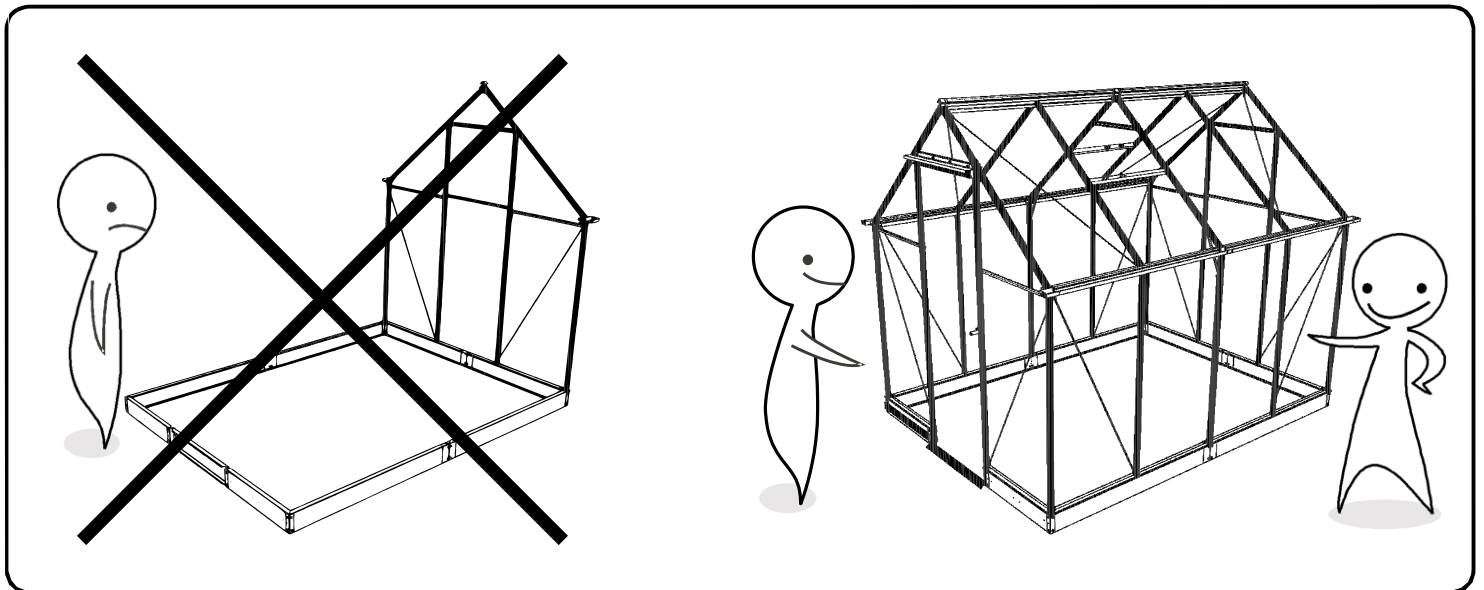
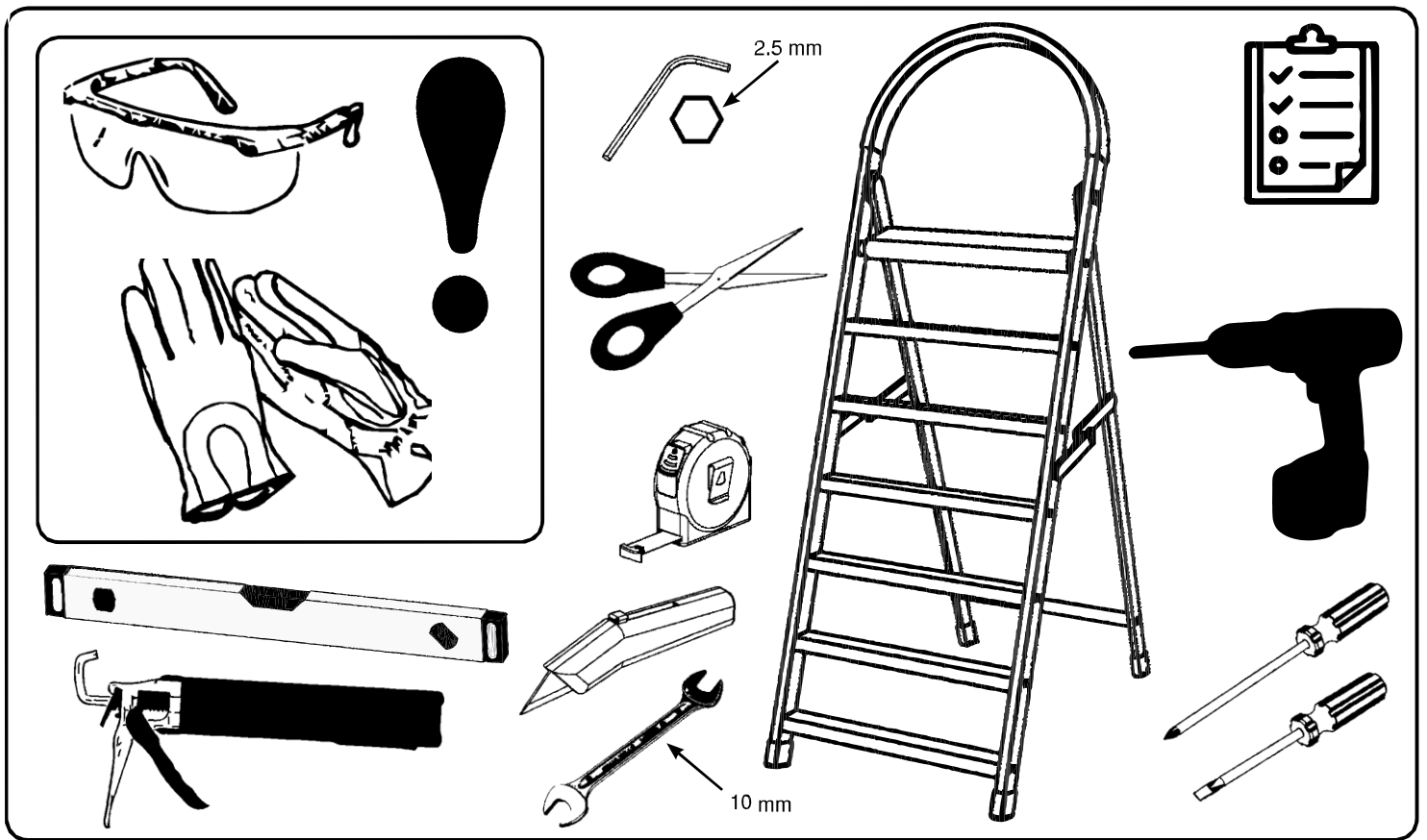

DENMARK:
+ 45 66 11 18 11

UK:
+ 44 (0) 1242 676625

GERMANY:
+ 49 (0) 1805 136 143

EESTI:
+ 372 505 1409



GB: Confirm parts are present
 DK: Bekræft dele er til stede
 G: Bestätigen Teile sind vorhanden
 S: Bekräfta delar är närvarande
 F: Confirmer les pièces sont présentes
 NL: Bevestig de onderdelen zijn aanwezig
 E: Confirmar que las partes están presentes
 I: Confermare le parti sono presenti
 FI: Varmista, että osat ovat läsnä
 PL: Potwierdź części są obecne
 N: Bekreft at deler er til stede

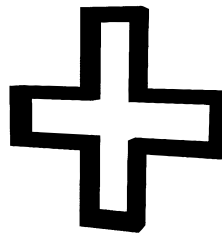

GB: Additional
 DK: Ekstra
 G: Zusätzlich
 S: Ytterligare
 F: Additionnel
 NL: Extra
 E: Adicional
 I: addizionale
 FI: lisä-
 PL: Dodatkowy
 N: Ytterligere

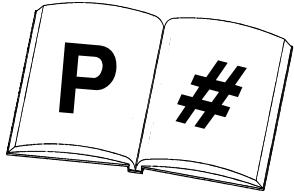

GB: Displayed on page(s)
 DK: Vises på side (r)
 G: Auf Seite (n) angezeigt
 S: Visas på sida (s)
 F: Affiché sur page (s)
 NL: Weergegeven op pagina ('s)
 E: Se muestra en la página (s)
 I: Visualizzato sulla pagina (s)
 FI: Näytetty sivulla (t)
 PL: Wyświetlane na stronie (s)
 N: Vises på side (r)



GB: Look Important step
 DK: Se vigtige trin
 G: Schau wichtiger Schritt
 S: Se viktigt steg
 F: Regarder l'étape importante
 NL: Zie belangrijke stap
 E: Mira paso importante
 I: Guarda passo importante
 FI: Katso tärkeä askel
 PL: Zobacz ważny krok
 N: Se viktig trinn



GB: Mirrored
 DK: Spejlet
 G: Gespiegelt
 S: Speglade
 F: En miroir
 NL: Gespiegeld
 E: Espejado
 I: Rispecchiato
 FI: Peilattu
 PL: Lustrzane odbicie
 N: Speiles

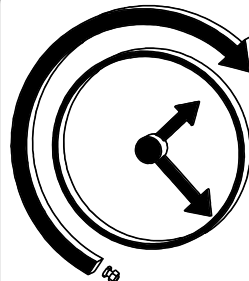

GB: For use in later step
 DK: Til brug i senere trin
 G: Für den späteren Schritt
 S: För användning i senare steg
 F: Pour une utilisation ultérieure
 NL: Voor gebruik in een latere stap
 E: Para usar en el paso posterior
 I: Da utilizzare nel passaggio successivo
 FI: Käytetään myöhemmin
 PL: Do użytku w późniejszym kroku
 N: For bruk i senere trinn

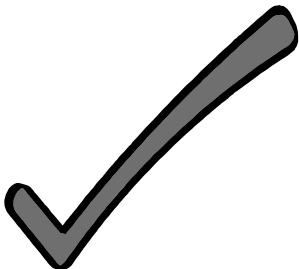

GB: Correct
 DK: korrekt
 G: Richtig
 S: Korrekt
 F: Correct
 NL: Correct
 E: Correcto
 I: Corretta
 FI: Oikea
 PL: Poprawny
 N: Riktig



www.hallsgreenhouses.com/help-and-advice

GB: See online video
 DK: Se online video
 G: Siehe Online-Video
 S: Se online video
 F: Voir la vidéo en ligne
 NL: Bekijk online video
 E: Ver video online
 I: Guarda il video online
 FI: Katso verkkovideo
 PL: Zobacz wideo online
 N: Se online video



GB: Think / Choose
 DK: Tænk / Vælg
 G: Denken / Wählen
 S: Tänk / välj
 F: Pensez / Choisissez
 NL: Denk / kies
 E: Pensar / elegir
 I: Pensa / scegli
 FI: Ajattele / Valitse
 PL: Pomyśl / wybierz
 N: Tenk / velg

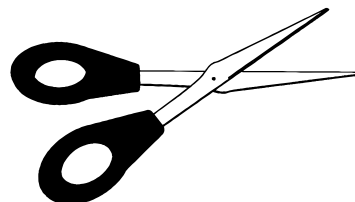

GB: Cut
 DK: Klip
 G: Schnitt
 S: Skära
 F: Couper
 NL: Besnoeiing
 E: Cortar
 I: Tagliare
 FI: Leikata
 PL: Ciąć
 N: Kutte opp

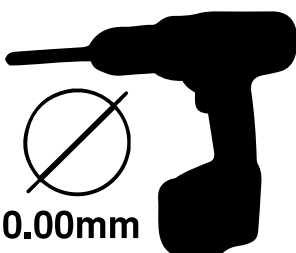

GB: Pilot / Drill
 DK: Pilot / Drill
 G: Pilot / Bohrer
 S: Pilot / Drill
 F: Pilote / Drill
 NL: Pilot / boor
 E: Piloto / Taladro
 I: Pilota / trapano
 FI: Pilotti / porata
 PL: Pilot / Drill
 N: Pilot / Drill

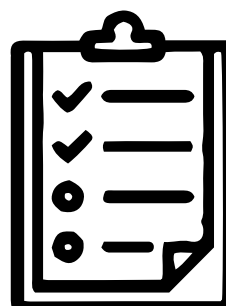

GB: May require
 DK: Kan kræve
 G: Kann verlangen
 S: Kan kräva
 F: Peut nécessiter
 NL: Kan vereisen
 E: Podría requerir
 I: Può richiedere
 FI: Voi vaatia
 PL: Może wymagać
 N: Kan kreve

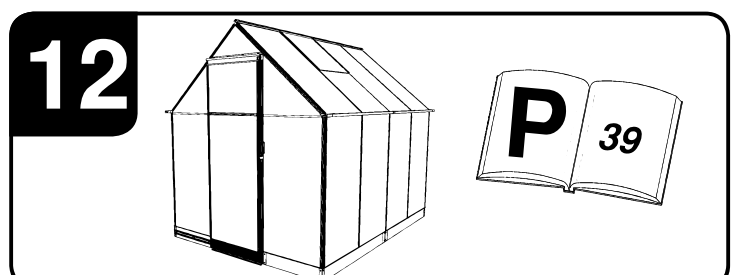
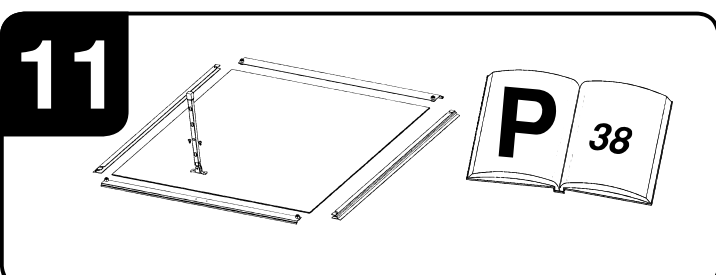
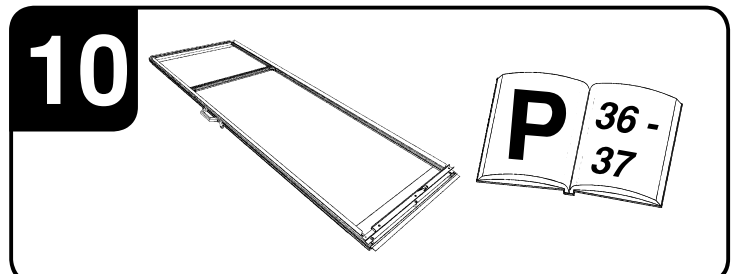
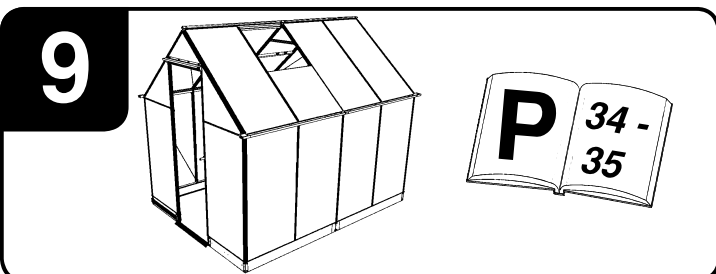
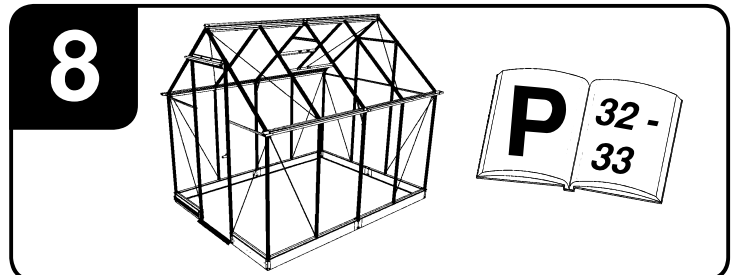
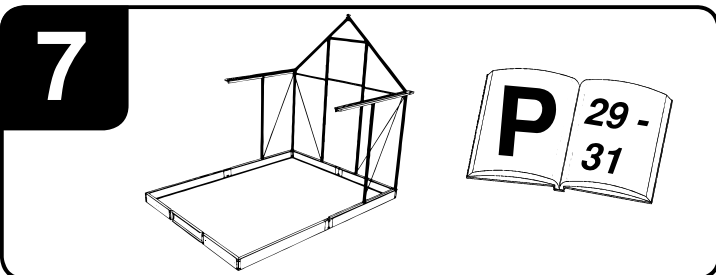
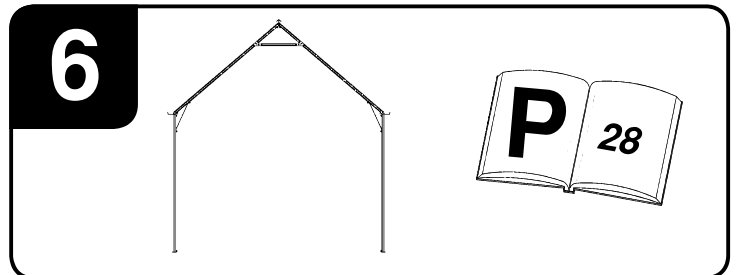
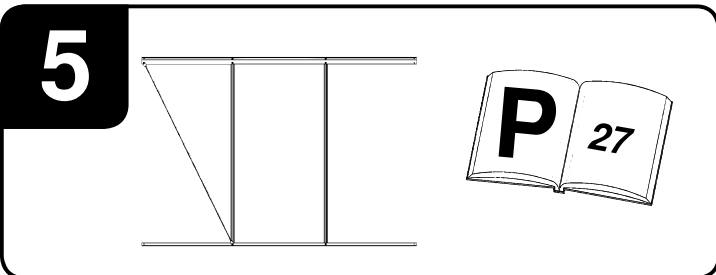
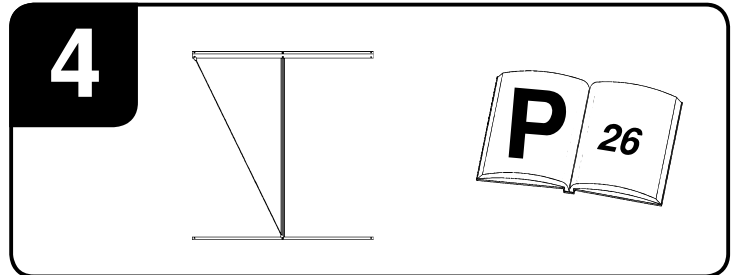
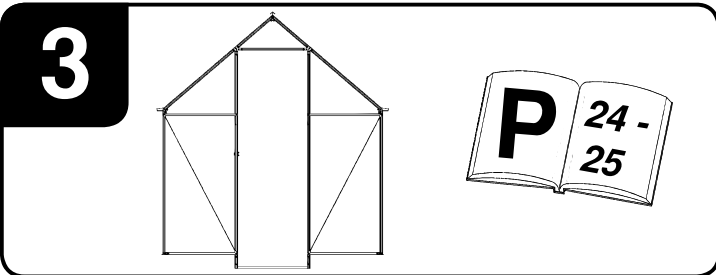
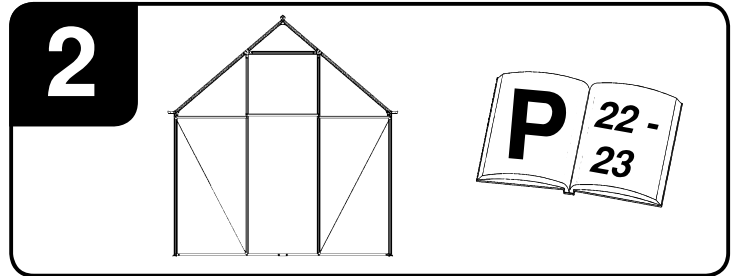
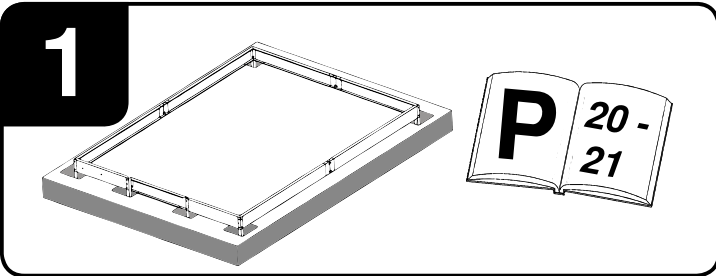
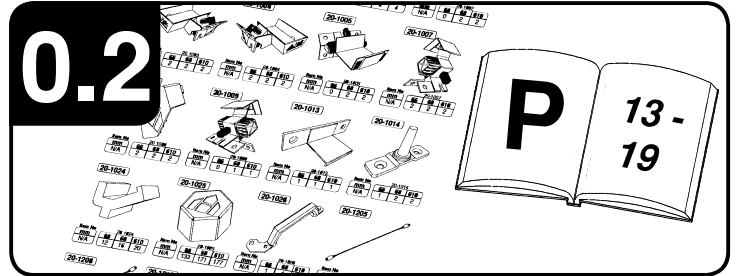
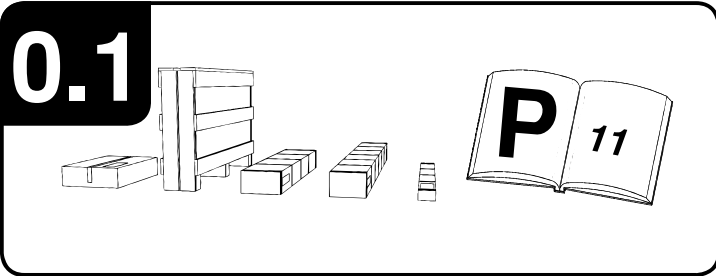

66
3,9 m²

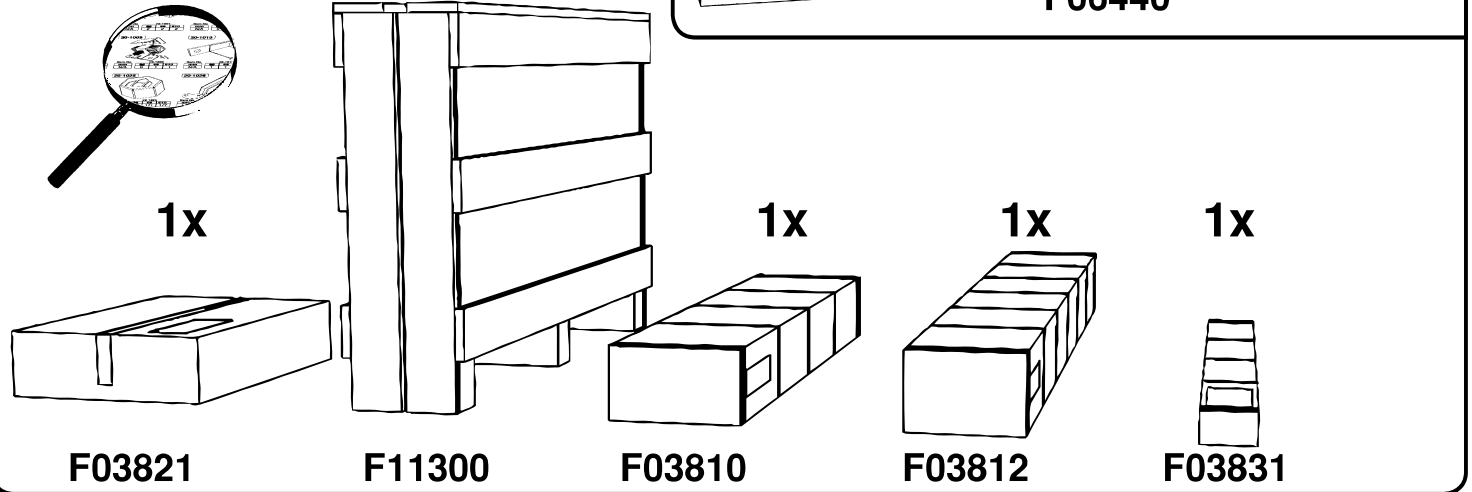

68
5,1 m²

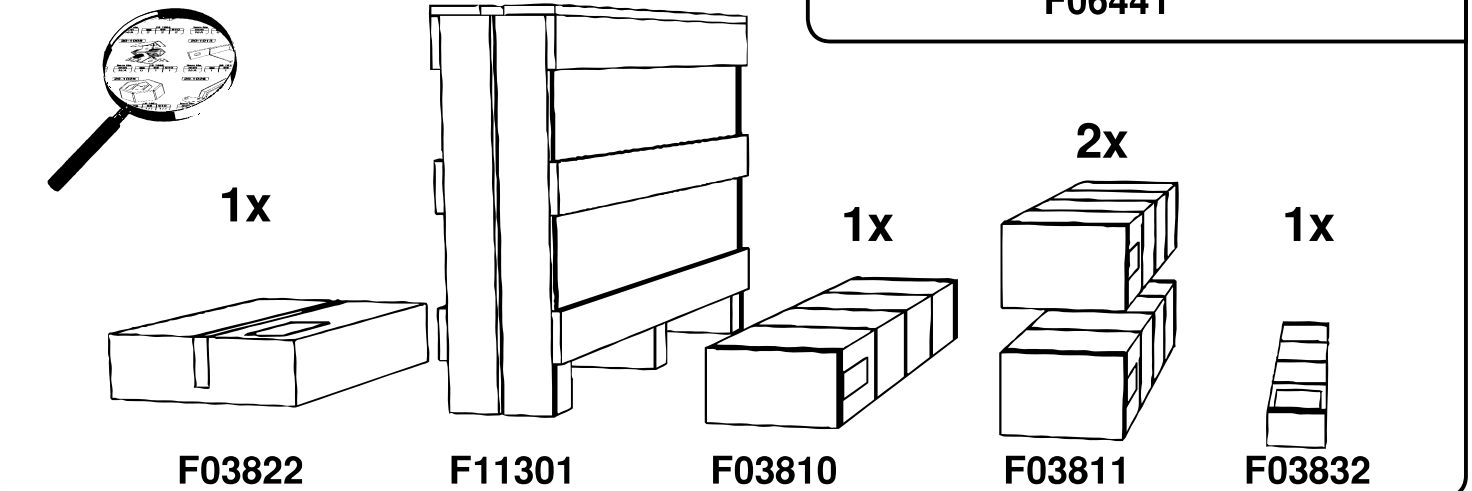

610
6,4 m²

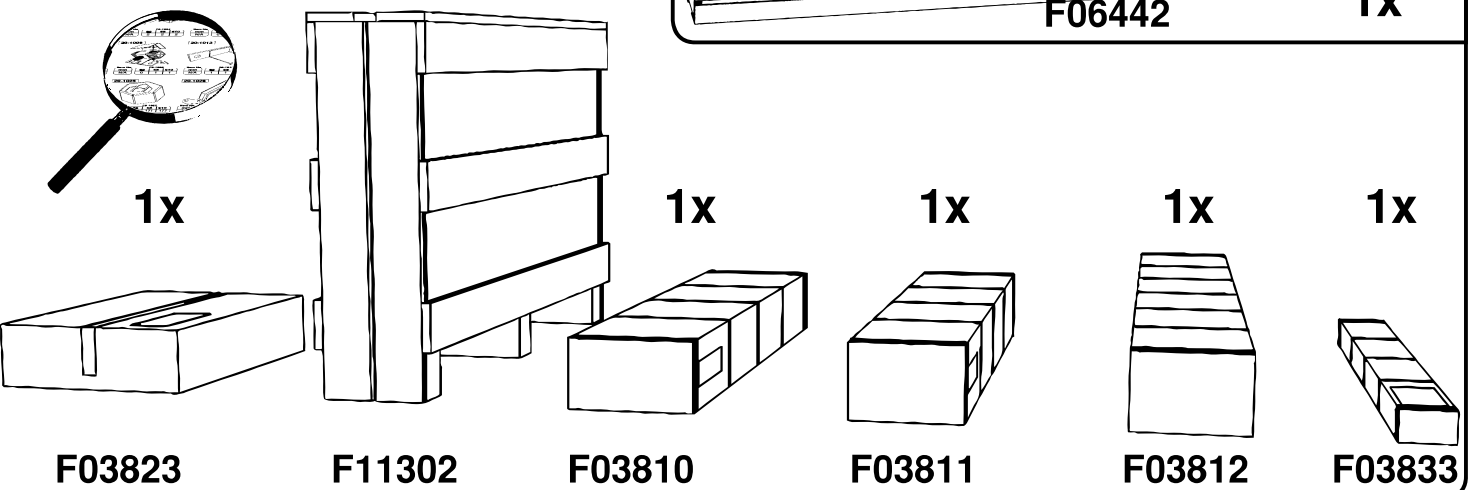

66 (3,9 m²) - F06440

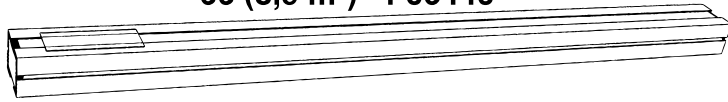

68 (5,1 m²) - F06441

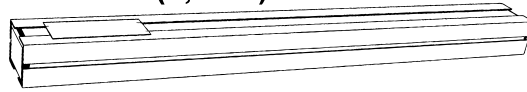

610 (6,4 m²) - F06442

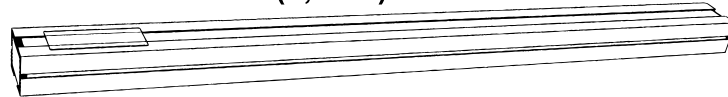

638

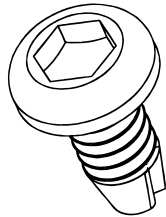

Item No:	00300638		
mm	66	68	610
N/A	2	6	6

992

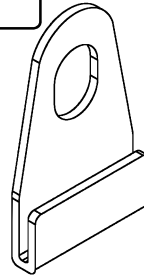

Item No:	00500992		
mm	66	68	610
N/A	12	14	18

995

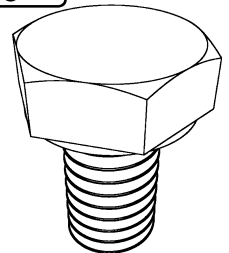

Item No:	00500995		
mm	66	68	610
M6 x 10	28	36	36

996

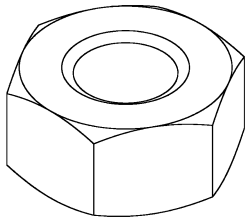

Item No:	00500996		
mm	66	68	610
M6	28	36	36

999

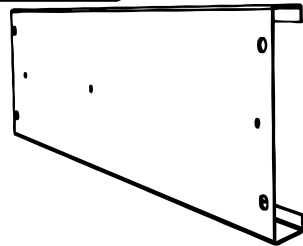

Item No:	00500999		
mm	66	68	610
618	1	1	1

100

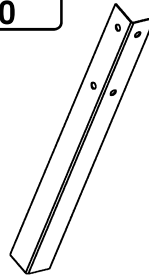

Item No:	00501000		
mm	66	68	610
345	4	4	4

100LH

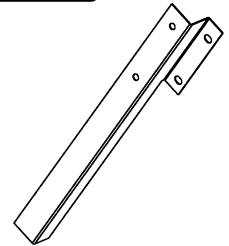

Item No:	0050100LH		
mm	66	68	610
345	1	1	1

100RH

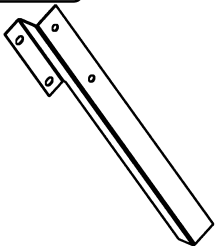

Item No:	0050100RH		
mm	66	68	610
345	1	1	1

101

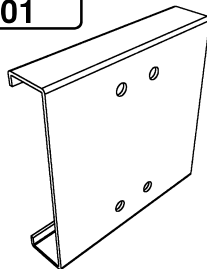

Item No:	0050101		
mm	66	68	610
120	1	3	3

102-1

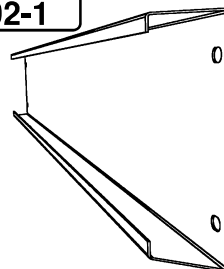

Item No:	0050102-1		
mm	66	68	610
618	1	1	1

102-2

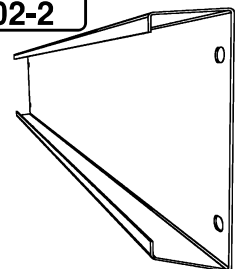

Item No:	0050102-2		
mm	66	68	610
941	2	2	2

102-3

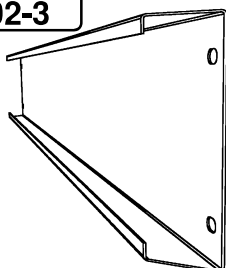

Item No:	0050102-3		
mm	66	68	610
1250	0	4	2

102-4

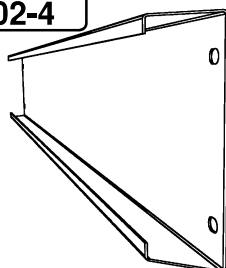

Item No:	0050102-4		
mm	66	68	610
1885	2	0	0

102-5

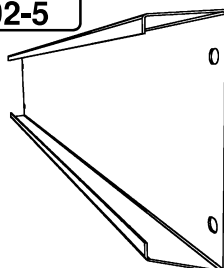

Item No:	0050102-5		
mm	66	68	610
1872	0	0	2

102-6

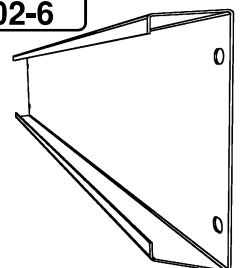

Item No:	0050102-6		
mm	66	68	610
642	1	1	1

66 (3,9 m²) - F03821

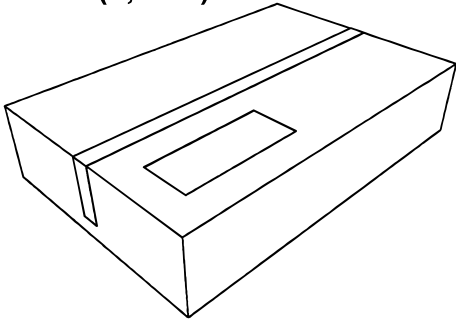

68 (5,1 m²) - F03822

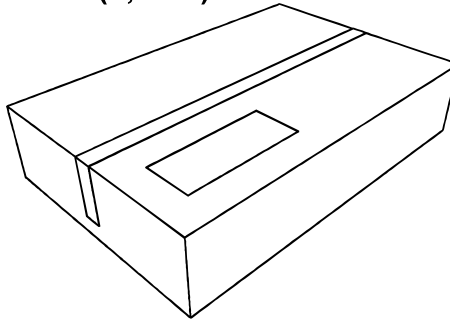

610 (6,4 m²) - F03823

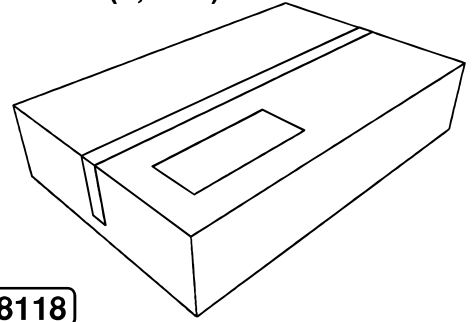

206S F018119

301 F018114

322 F018118

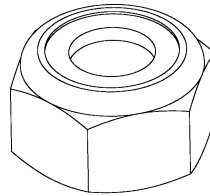
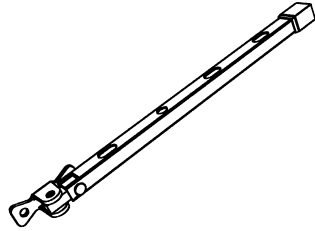
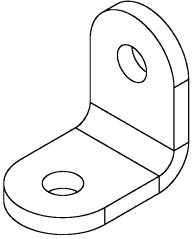

Item No:	00310206S		
mm	66	68	610
N/A	2	2	2

Item No:	RN00300301		
mm	66	68	610
N/A	1	2	2

Item No:	RN00300322		
mm	66	68	610
M6	3	3	3

350

400 F018112/15

402 F018118

602 F018118

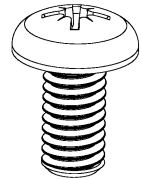
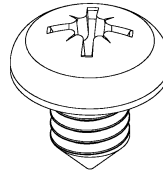
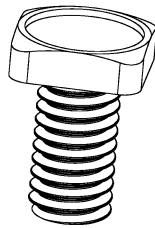

Item No:	00300350		
ml	66	68	610
310	1	1	1

Item No:	00400		
mm	66	68	610
M6 x 10	130	168	174

Item No:	00402		
mm	66	68	610
No6 x 6	6	12	12

Item No:	N00300602		
mm	66	68	610
M4 x 8	12	12	12

604 F018118

617 F018126

618 F018125

631 F018118

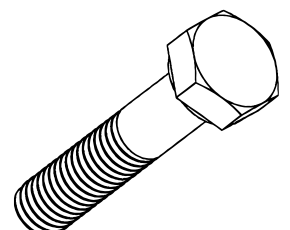
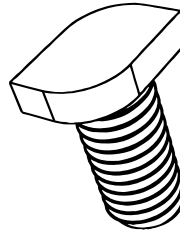
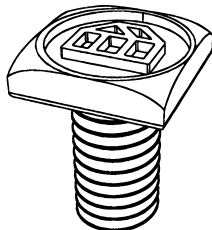
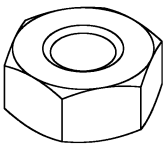

Item No:	N00300604		
mm	66	68	610
M4	12	12	12

Item No:	00300617		
mm	66	68	610
M6 x 11	4	8	8

Item No:	00300618		
mm	66	68	610
M6 x 11	2	4	4

Item No:	RN00300631		
mm	66	68	610
M6	3	3	3

697 F018112/15

1645 F018118

20-1001 F01896

20-1002 F018110

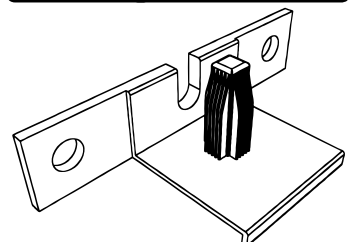
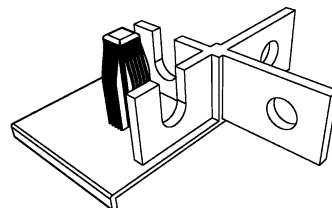
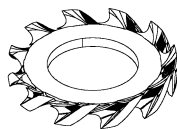
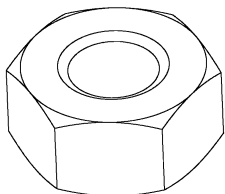

Item No:	00697		
mm	66	68	610
M6	130	168	174

Item No:	01645		
mm	66	68	610
M4	12	12	12

Item No:	20-1001		
mm	66	68	610
N/A	4	4	4

Item No:	20-1002		
mm	66	68	610
N/A	0	2	2

20-1003 F01897

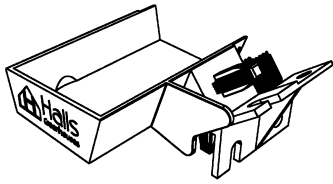

Item No:	20-1003		
mm	66	68	610
N/A	2	2	2

20-1004 F01898

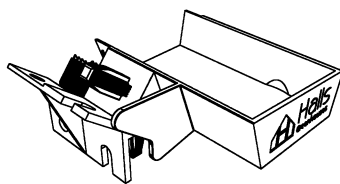

Item No:	20-1004		
mm	66	68	610
N/A	2	2	2

20-1005 F018109

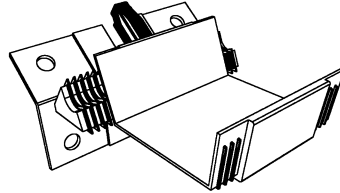

Item No:	20-1005		
mm	66	68	610
N/A	0	2	2

20-1007 F01899

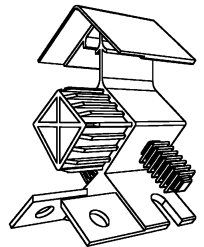

Item No:	20-1007		
mm	66	68	610
N/A	2	2	2

20-1008 F018100

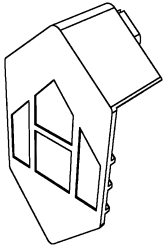

Item No:	20-1008		
mm	66	68	610
N/A	2	2	2

20-1009 F018109

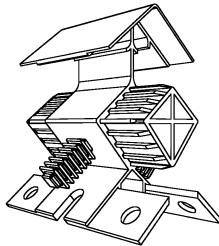

Item No:	20-1009		
mm	66	68	610
N/A	0	1	1

20-1013 F018103

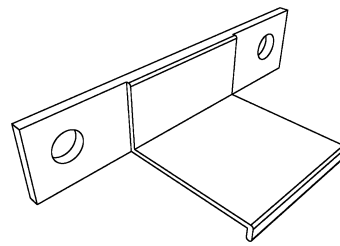

Item No:	20-1013		
mm	66	68	610
N/A	1	1	1

20-1014 F018111

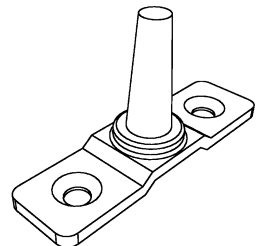

Item No:	20-1014		
mm	66	68	610
N/A	2	4	4

20-1024 F018105

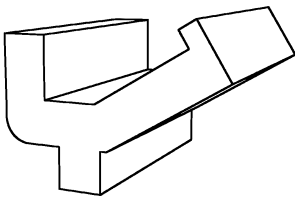

Item No:	20-1024		
mm	66	68	610
N/A	12	16	20

20-1025 F018101/02

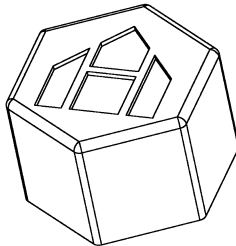

Item No:	20-1025		
mm	66	68	610
N/A	133	171	177

20-1026 F018104

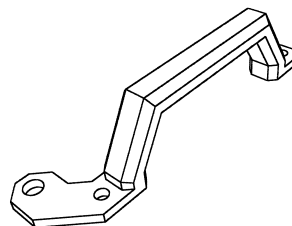

Item No:	20-1026		
mm	66	68	610
N/A	1	1	1

20-1205 F018104/05

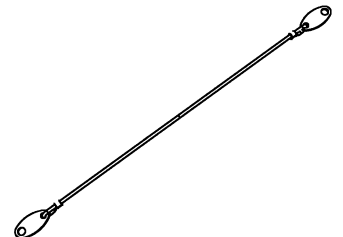

Item No:	20-1205		
mm	66	68	610
1309	2	4	4

20-1206 F018106/07

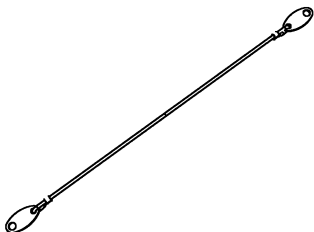

Item No:	20-1206		
mm	66	68	610
1337	6	8	8

20-1210 F01892

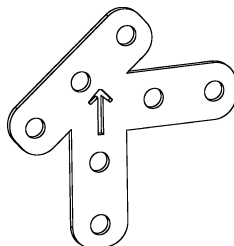

Item No:	20-1210		
mm	66	68	610
N/A	4	4	4

20-1213 F01893

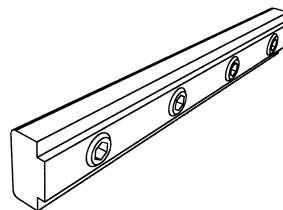

Item No:	20-1213		
mm	66	68	610
N/A	12	12	12

20-1214 F01895

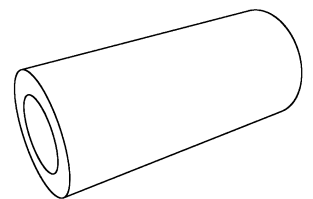

Item No:	20-1214		
mm	66	68	610
23.5	3	3	3

20-1215 F01894

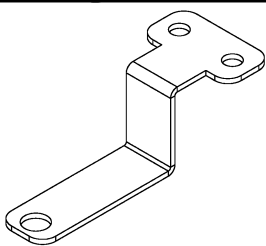

Item No:	20-1215		
mm	66	68	610
N/A	1	1	1

20-1217 F018108

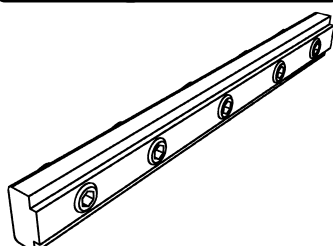

Item No:	20-1217		
mm	66	68	610
N/A	0	1	1

20-1218 F018108

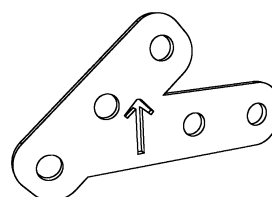

Item No:	20-1218		
mm	66	68	610
N/A	0	2	2

20-1230 F018117

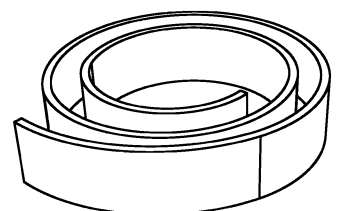

Item No:	20-1230		
mm	66	68	610
22000	3	4	4

66 (3,9 m²)

68 (5,1 m²) - F03810

610 (6,4 m²)

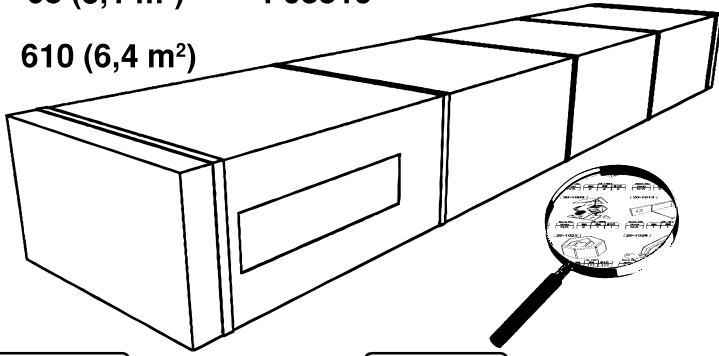

21S

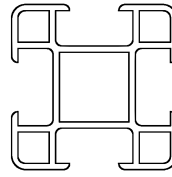

Item No:	20-40010635-21S		
mm	66	68	610
	2	2	2

22S

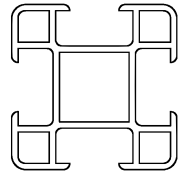

Item No:	20-4001515-22S		
mm	66	68	610
	2	2	2

31S

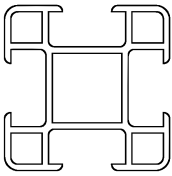

Item No:	20-40011225-31S		
mm	66	68	610
	10	10	10

51S

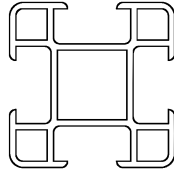

Item No:	20-40011202-51S		
mm	66	68	610
	4	4	4

55S

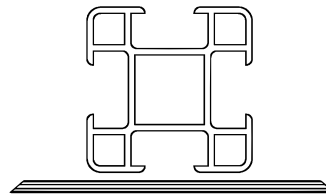

Item No:	20-40010642-55S		
mm	66	68	610
	2	2	2

09S



Item No:	20-40040613-09S		
mm	66	68	610
	1	1	1

10S



Item No:	20-40040613-10S		
mm	66	68	610
	1	1	1

201S



Item No:	20-40040895-201S		
mm	66	68	610
	1	1	1

202S



Item No:	20-40040895-202S		
mm	66	68	610
	1	1	1

19S



Item No:	20-40120640-19S		
mm	66	68	610
	5	5	5

00S

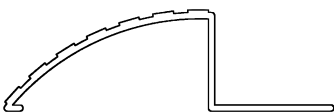

Item No:	20-40050642-00S		
mm	66	68	610
	1	1	1

08S

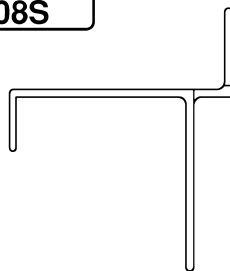

Item No:	20-40080655-08S		
mm	66	68	610
	1	1	1

56S

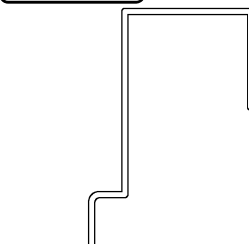

Item No:	20-40090642-56S		
mm	66	68	610
	1	1	1

57S

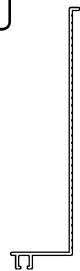

Item No:	20-40100642-57S		
mm	66	68	610
	1	1	1

58S



Item No:	20-40190642-58S		
mm	66	68	610
	1	1	1

59S

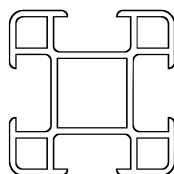

Item No:	20-40010595-59S		
mm	66	68	610
	3	3	3

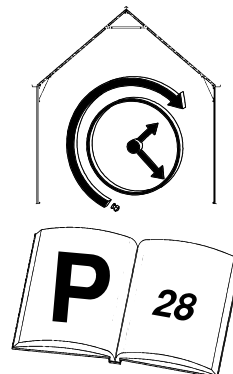

54S

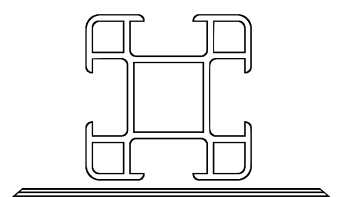

Item No:	20-40010420-54S		
mm	66	68	610
	0	1	1

68 (5,1 m²)
610 (6,4 m²) - F03811

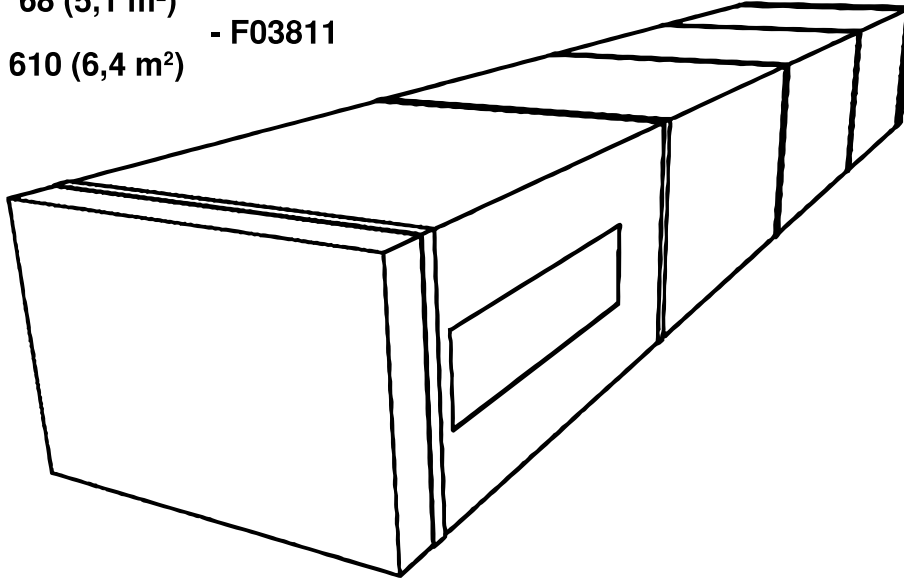

31S

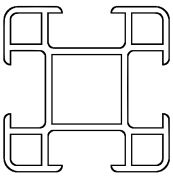

Item No:	20-40011225-31S		
mm	66	68	610
1225	0	4	2

302S

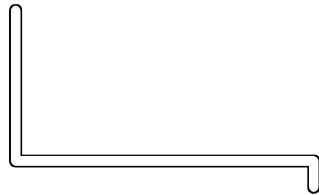

Item No:	20-40041204-302S		
mm	66	68	610
1204	0	4	2

322S

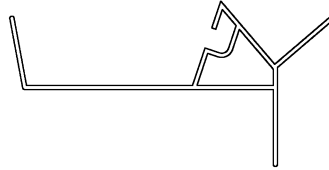

Item No:	20-40031204-322S		
mm	66	68	610
1204	0	4	2

51S

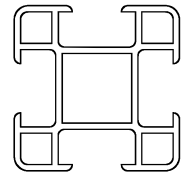

Item No:	20-40011202-51S		
mm	66	68	610
1202	0	4	2

502S

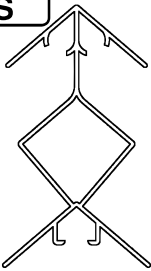

Item No:	20-40021204-502S		
mm	66	68	610
1204	0	2	1

70S



Item No:	20-40060592-70S		
mm	66	68	610
592	0	2	1

71S

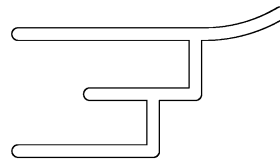

Item No:	20-40070608-71S		
mm	66	68	610
608	0	4	2

72S

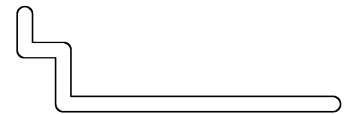

Item No:	20-40140592-72S		
mm	66	68	610
592	0	2	1

75S



Item No:	20-40200642-75S		
mm	66	68	610
642	0	2	1

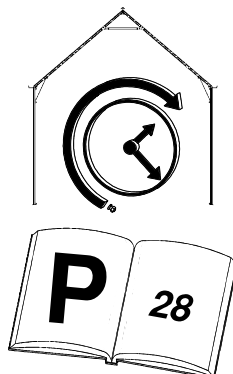

31S

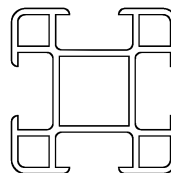

Item No:	20-40011225-31S		
mm	66	68	610
1225	0	1	1

51S

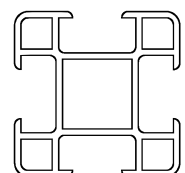

Item No:	20-40011202-51S		
mm	66	68	610
1202	0	1	1



66 (3,9 m²)
610 (6,4 m²) - F03812

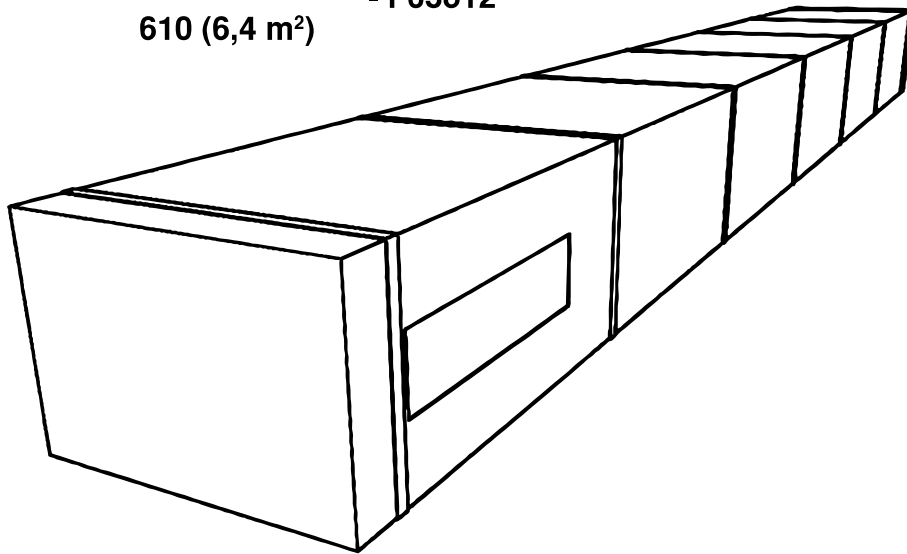

31S

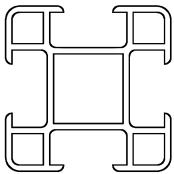

Item No:	20-40011225-31S		
mm	66	68	610
	4	0	4
1225			

303S



Item No:	20-40041823-303S		
mm	66	68	610
	2	0	2
1823			

323S

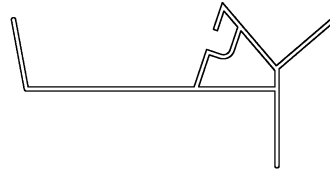

Item No:	20-40031823-323S		
mm	66	68	610
	2	0	2
1823			

51S

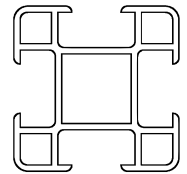

Item No:	20-40011202-51S		
mm	66	68	610
	4	0	4
1202			

503S

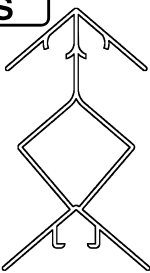

Item No:	20-40021823-503S		
mm	66	68	610
	1	0	1
1823			

70S



Item No:	20-40060592-70S		
mm	66	68	610
	0	2	1
592			

71S

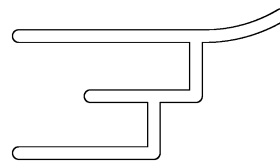

Item No:	20-40070608-71S		
mm	66	68	610
	0	4	2
608			

72S



Item No:	20-40140592-72S		
mm	66	68	610
	0	2	1
592			

75S

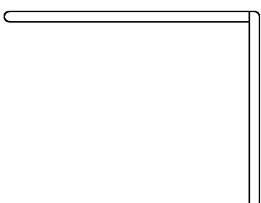

Item No:	20-40200642-75S		
mm	66	68	610
	0	2	1
642			

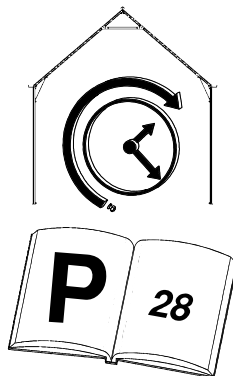

31S

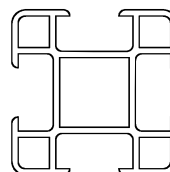

Item No:	20-40011225-31S		
mm	66	68	610
	0	1	1
1225			

51S

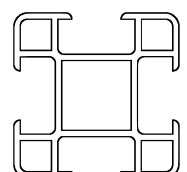

Item No:	20-40011202-51S		
mm	66	68	610
	0	1	1
1202			

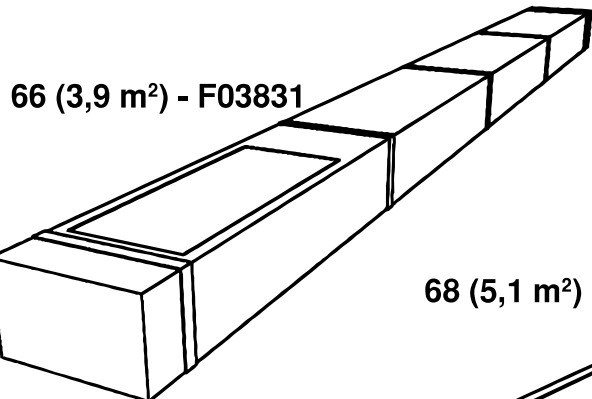

66 (3,9 m²) - F03831

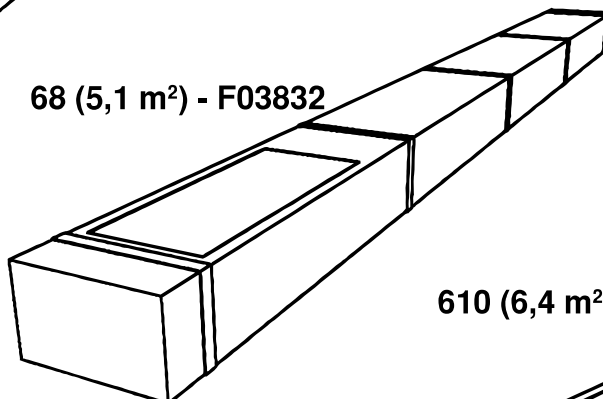

68 (5,1 m²) - F03832

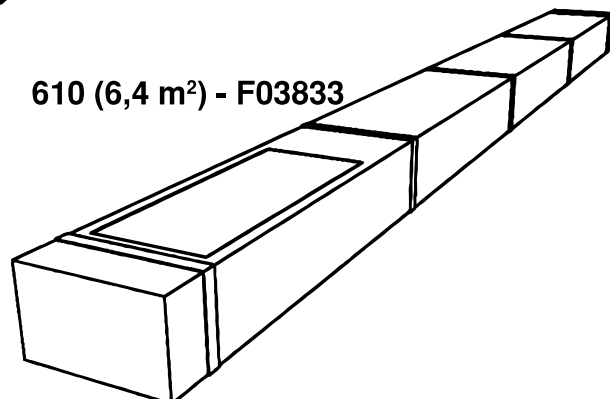

610 (6,4 m²) - F03833



80

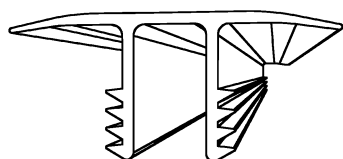

Item No:	7093080		
mm	66	68	610
1225	18	20	22

81

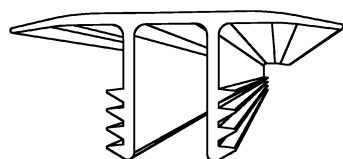

Item No:	7093081		
mm	66	68	610
1202	12	14	16

82

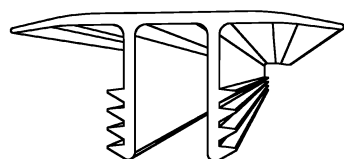

Item No:	7093082		
mm	66	68	610
512	4	4	4

83

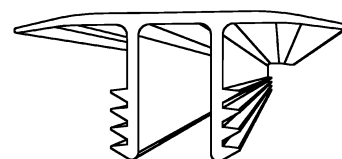

Item No:	7093083		
mm	66	68	610
450	2	2	2

84

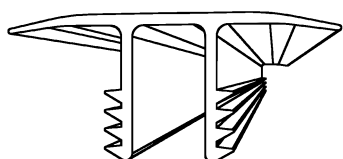

Item No:	7093084		
mm	66	68	610
595	1	1	1

437N

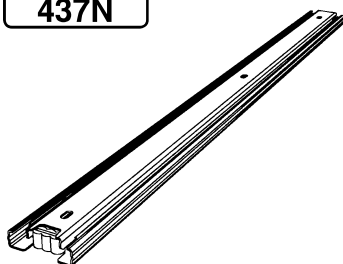

Item No:	RN00310437N		
mm	66	68	610
600	2	2	2

20-1030

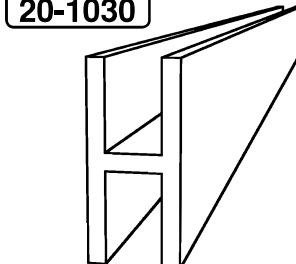

Item No:	20-1030		
mm	66	68	610
595	5	5	5

20-1203

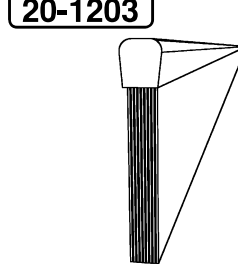

Item No:	20-1203		
mm	66	68	610
638	1	1	1

20-1204

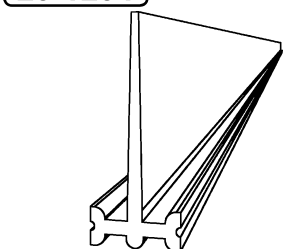

Item No:	20-1204		
mm	66	68	610
3520	1	1	1

40

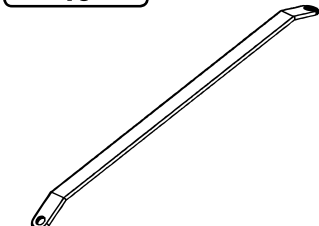

Item No:	RP235570300		
mm	66	68	610
300	0	2	2

66
3,9 m²
F06440

66	A (mm)	B (mm)	C (mm)	D (mm)
3,9m ²	1888	1888	621	646

68
5,1 m²
F06441

68	A (mm)	B (mm)	C (mm)	D (mm)
5,1m ²	1888	2507	621	646

610
6,4 m²
F06442

610	A (mm)	B (mm)	C (mm)	D (mm)
6,4m ²	1888	3126	621	646

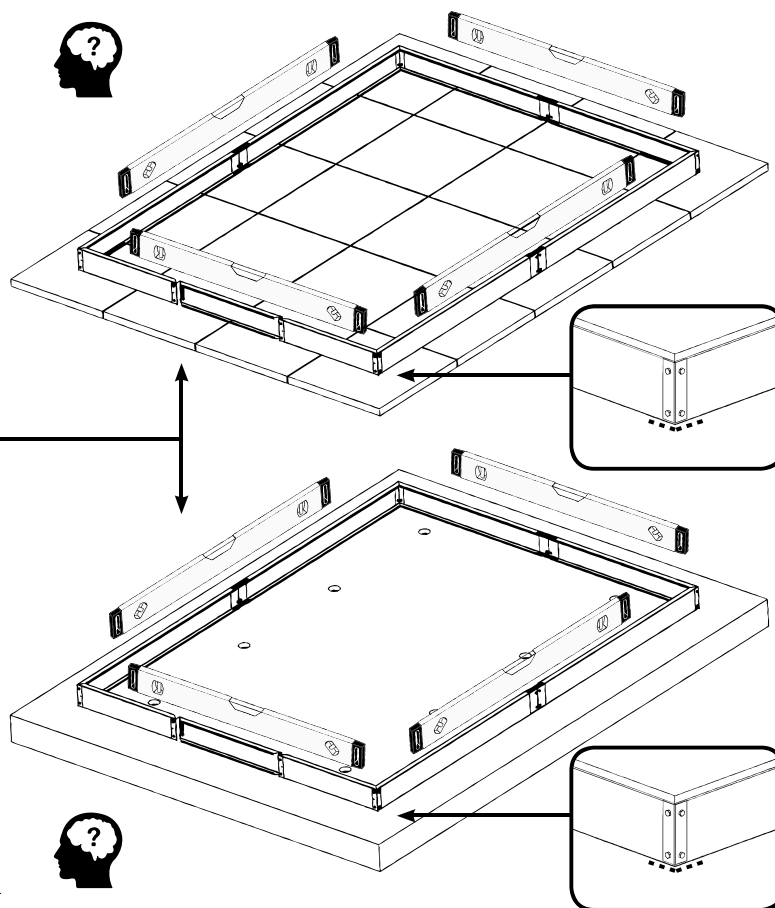
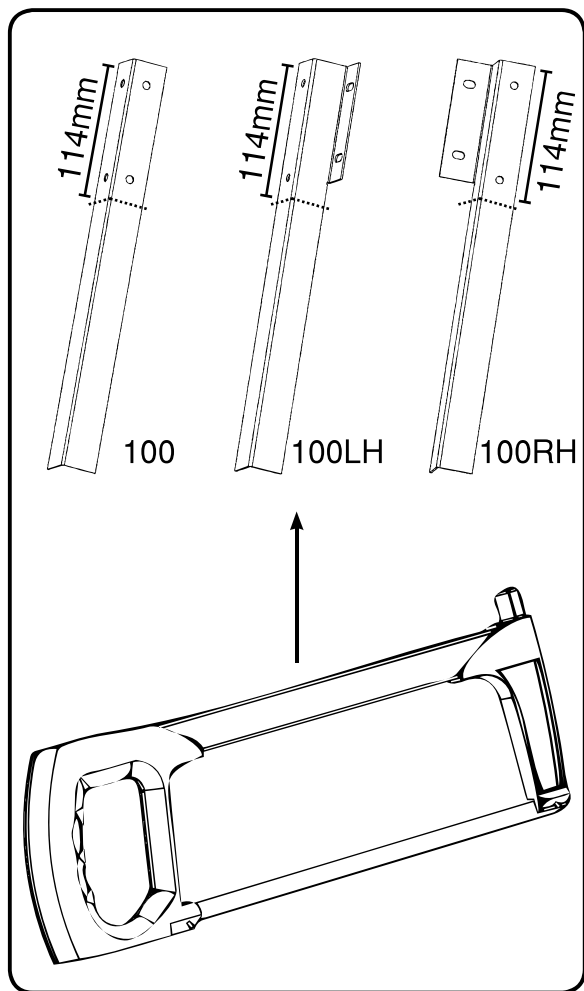
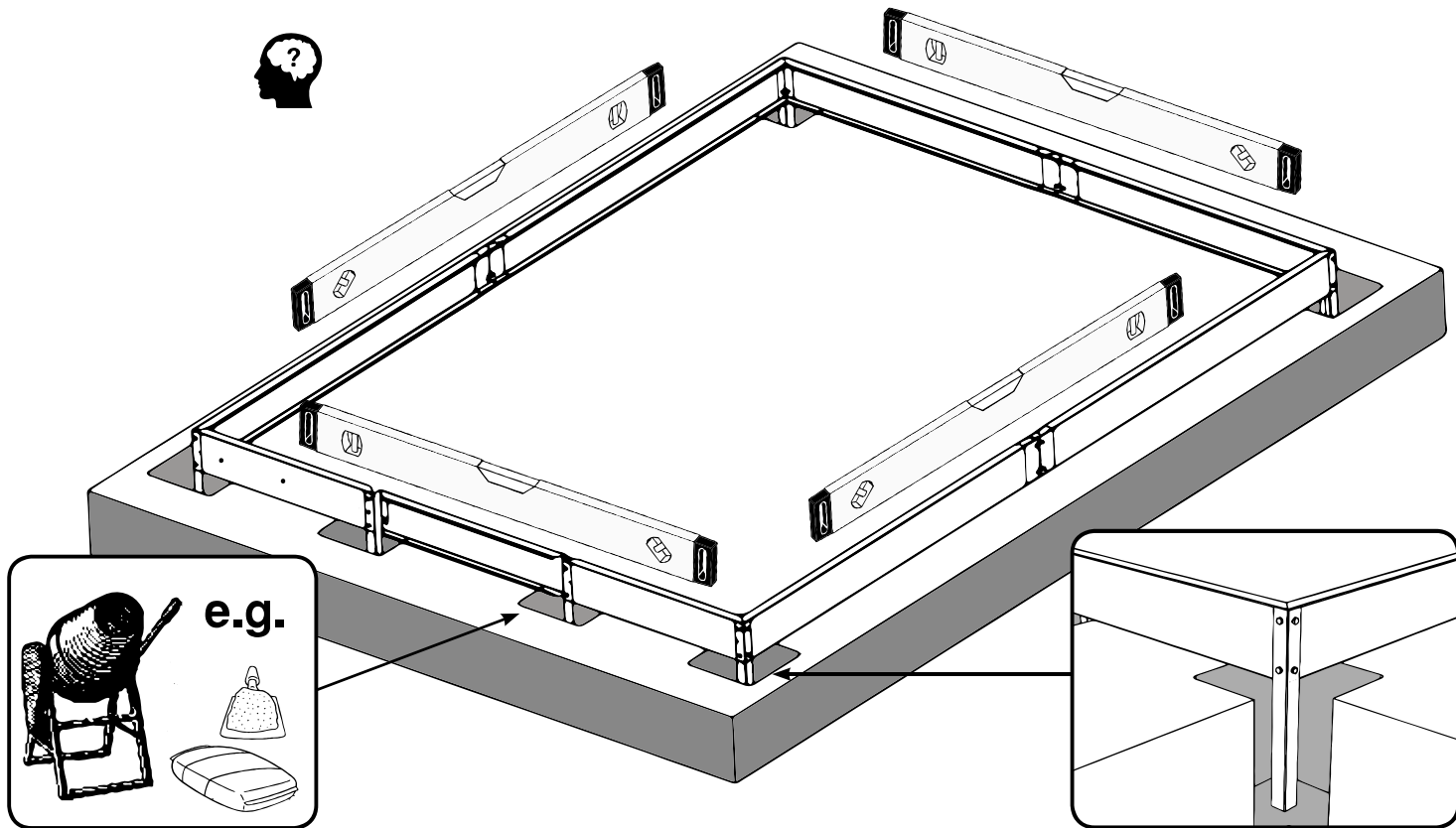

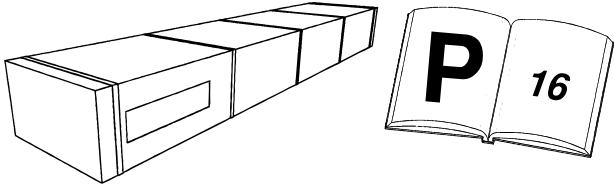

66 (3,9 m²) / 68 (5,1 m²) / 610 (6,4 m²) - F03810

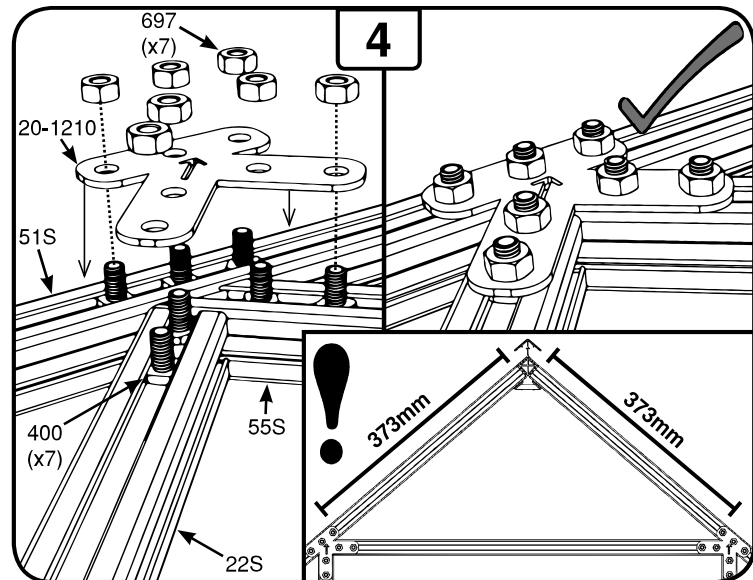
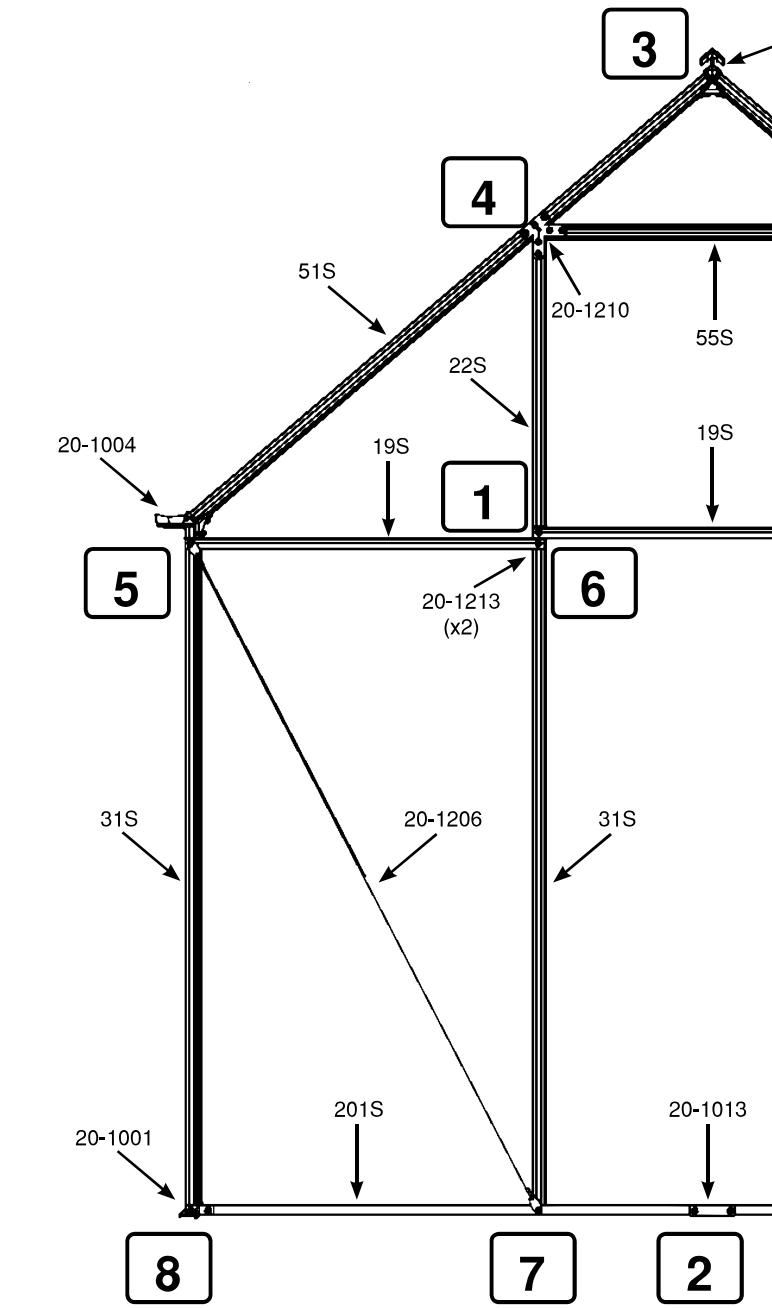
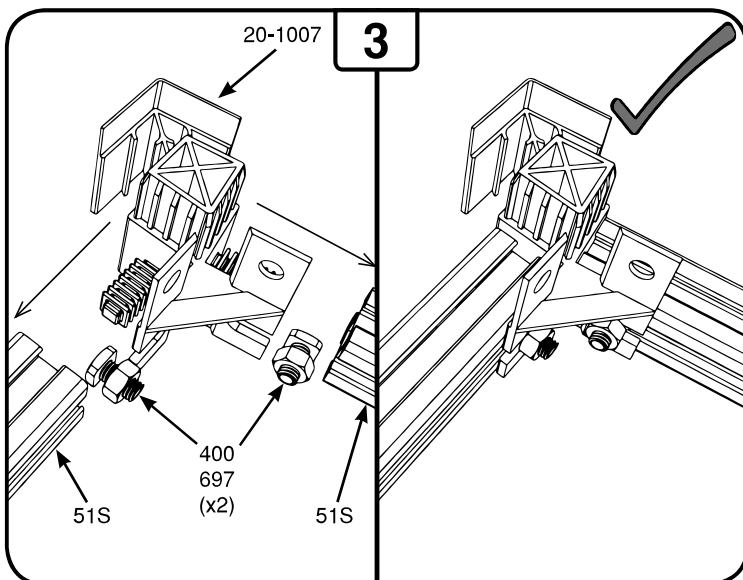
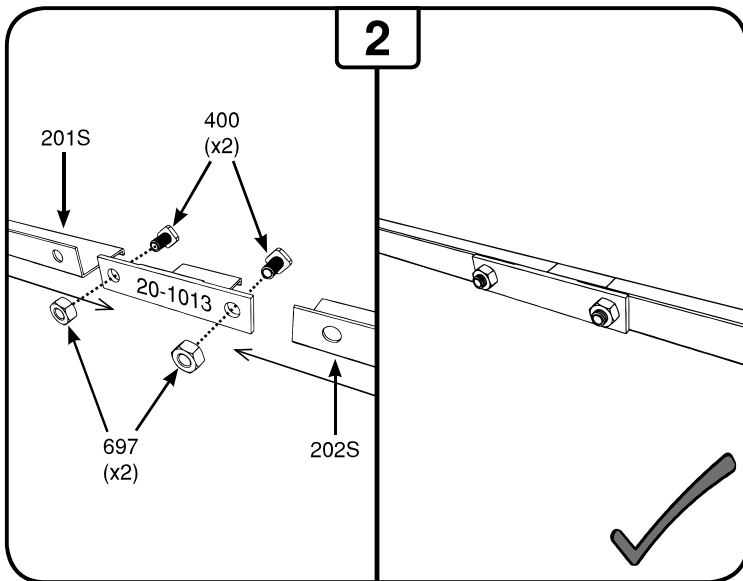
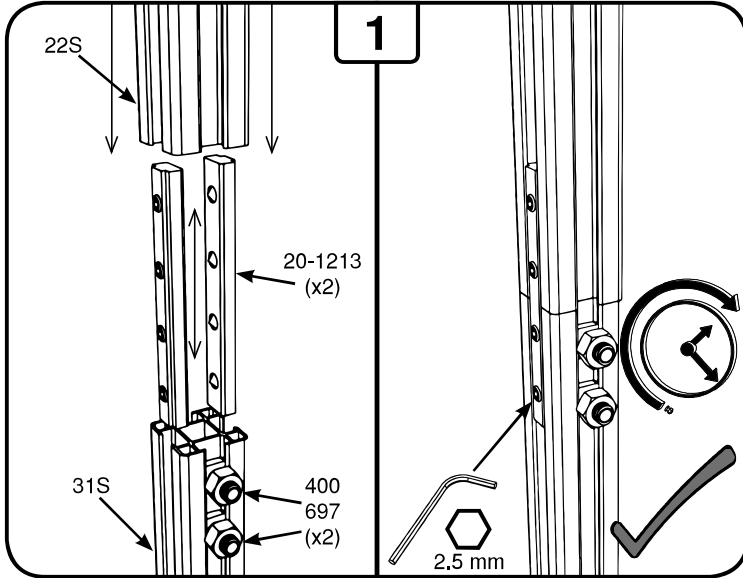

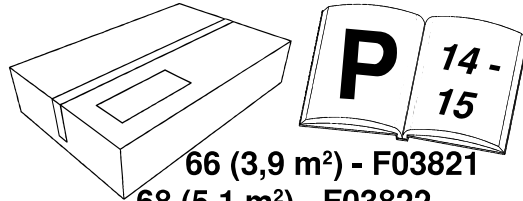

66 (3,9 m²) - F03821
 68 (5,1 m²) - F03822
 610 (6,4 m²) - F03823

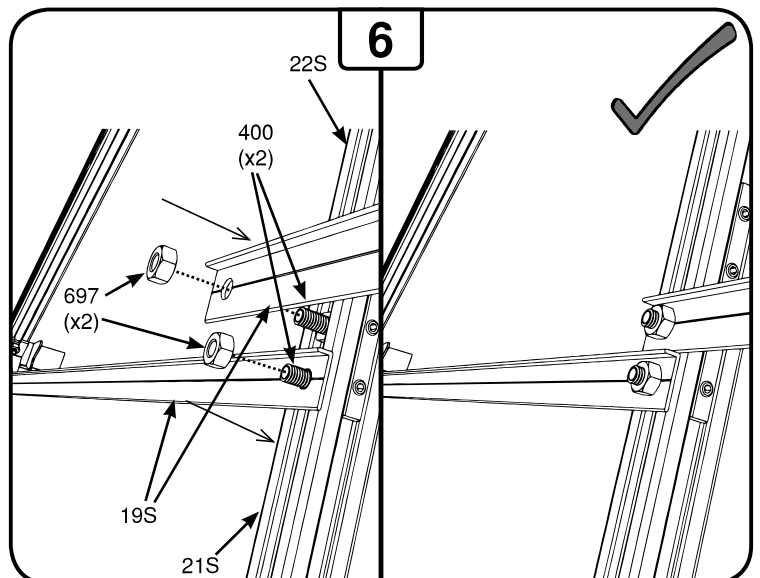
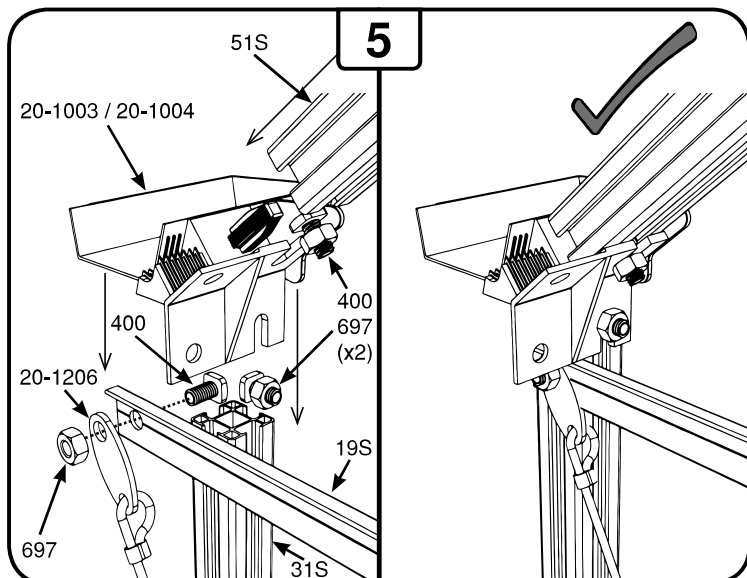
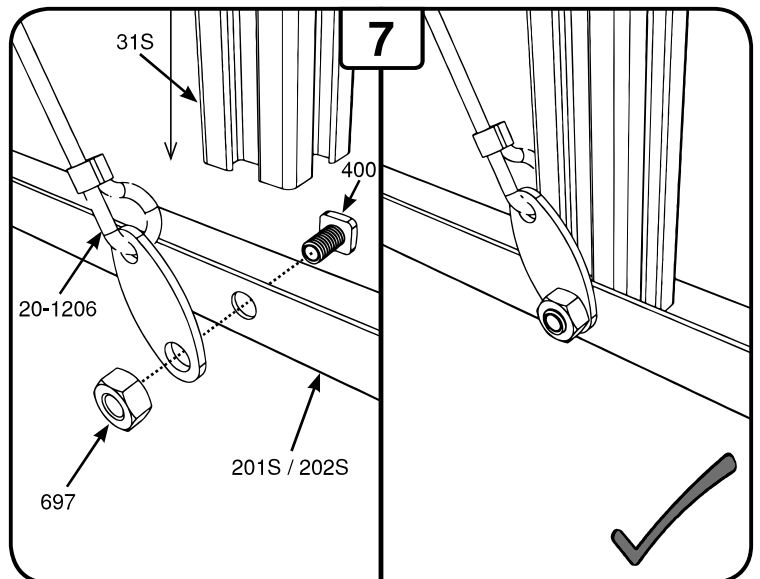
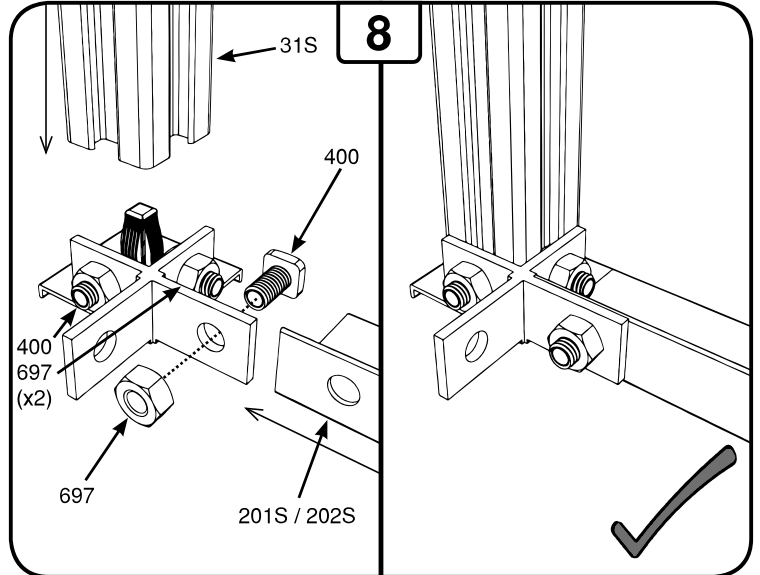
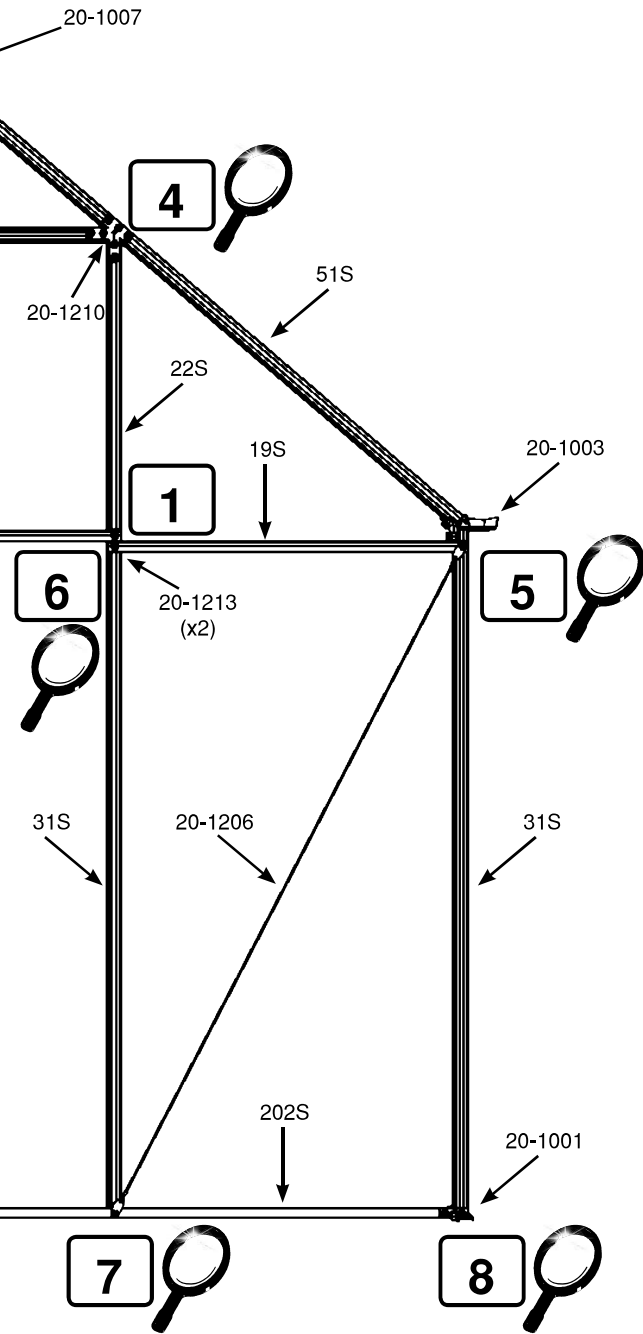

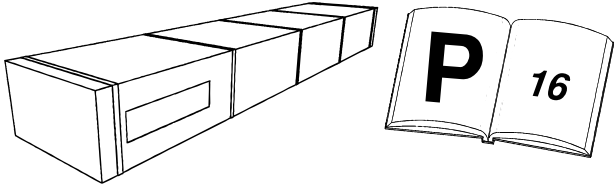

66 (3,9 m²) / 68 (5,1 m²) / 610 (6,4 m²) - F03810

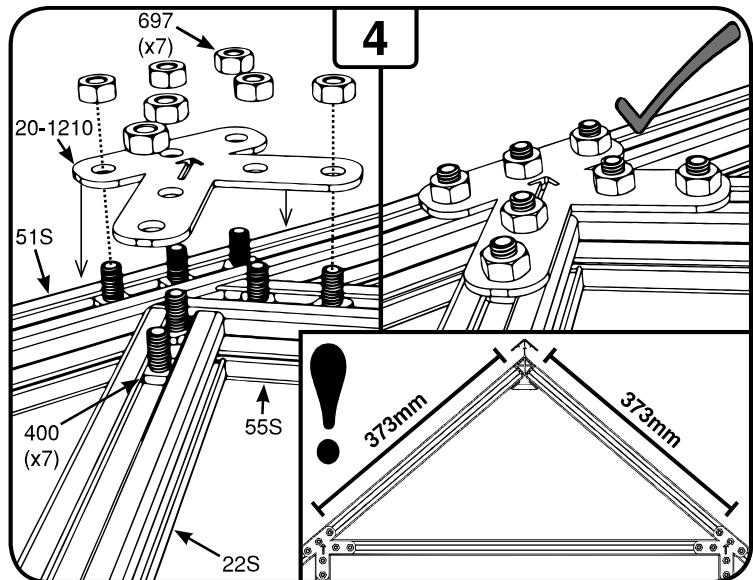
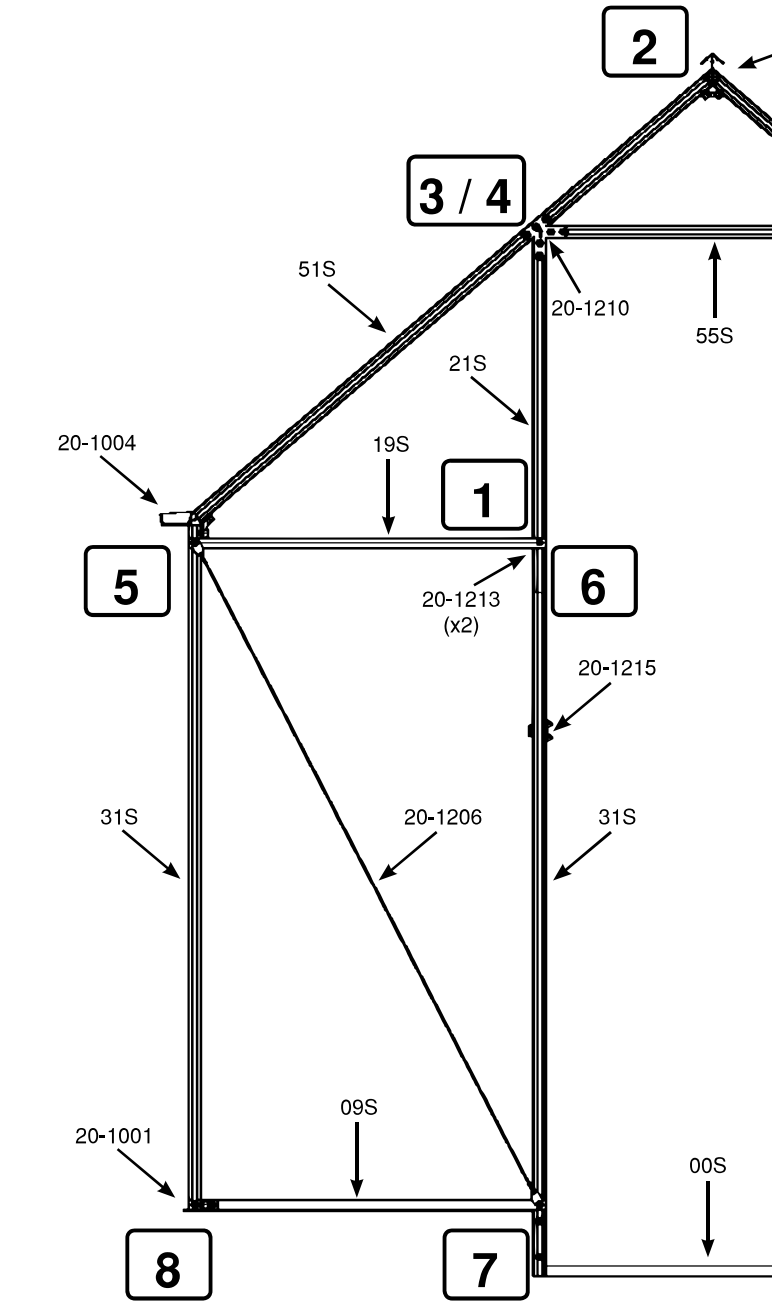
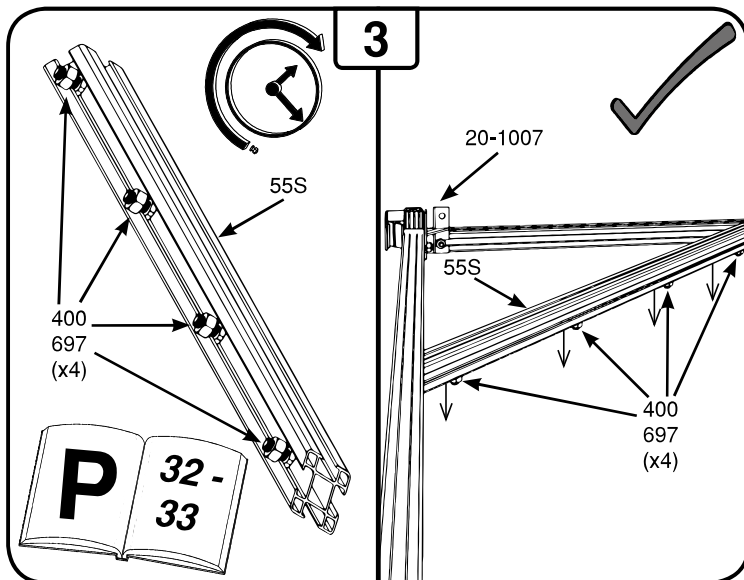
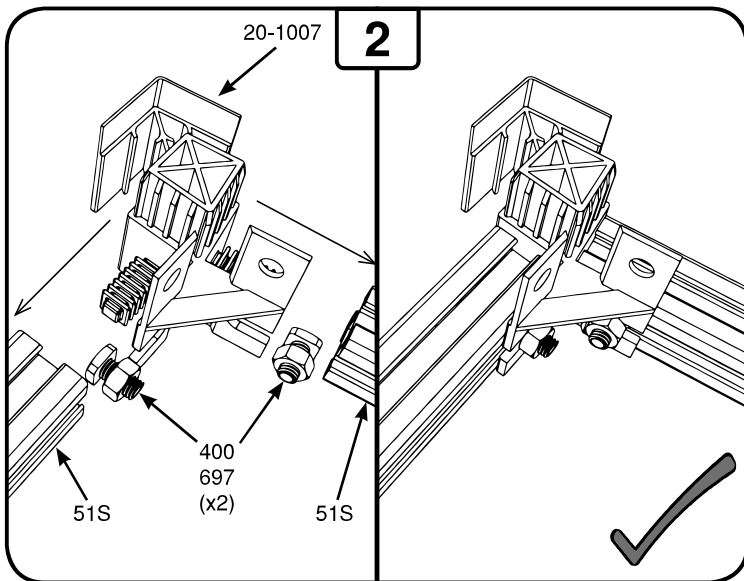
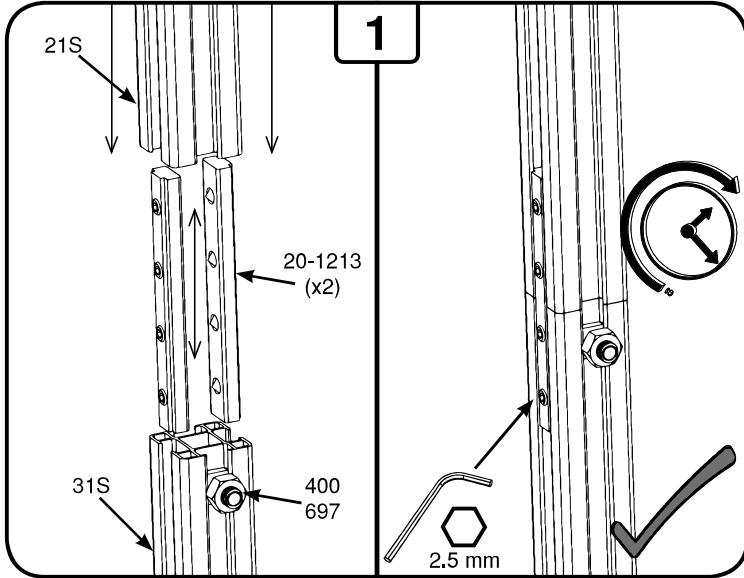

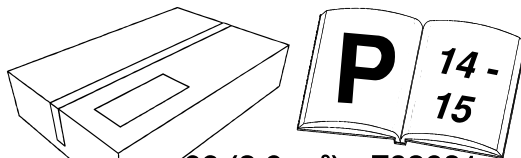

66 (3,9 m²) - F03821
 68 (5,1 m²) - F03822
 610 (6,4 m²) - F03823

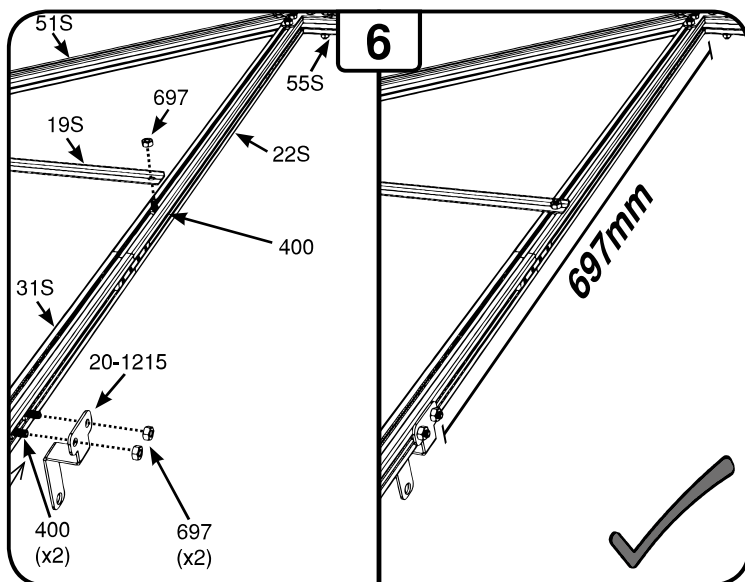
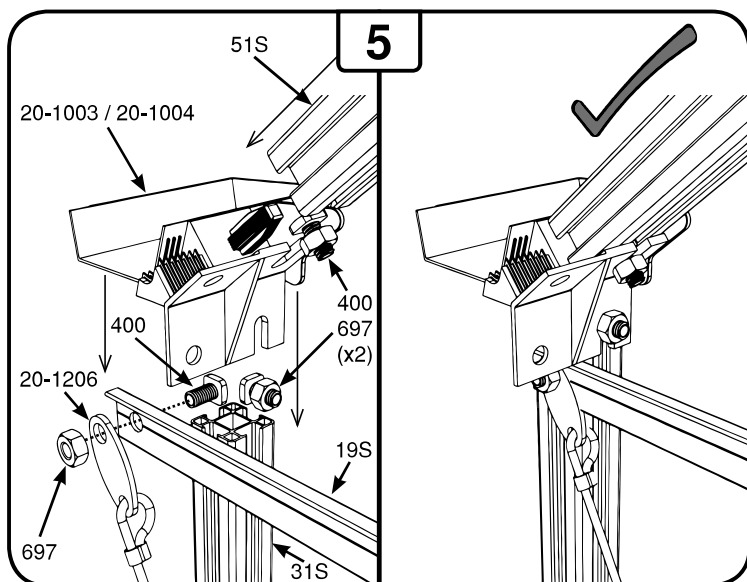
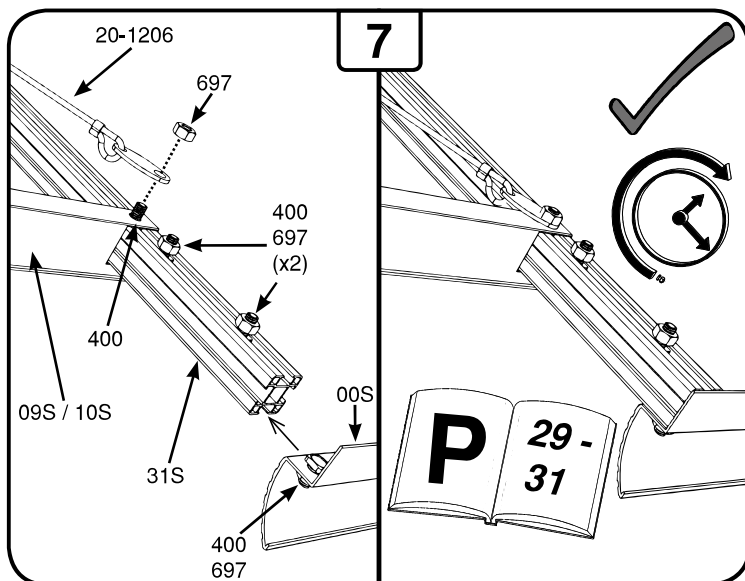
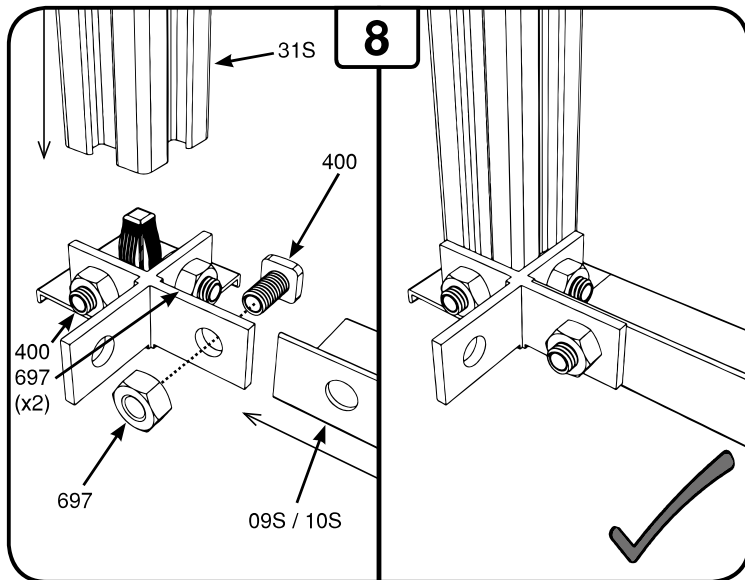
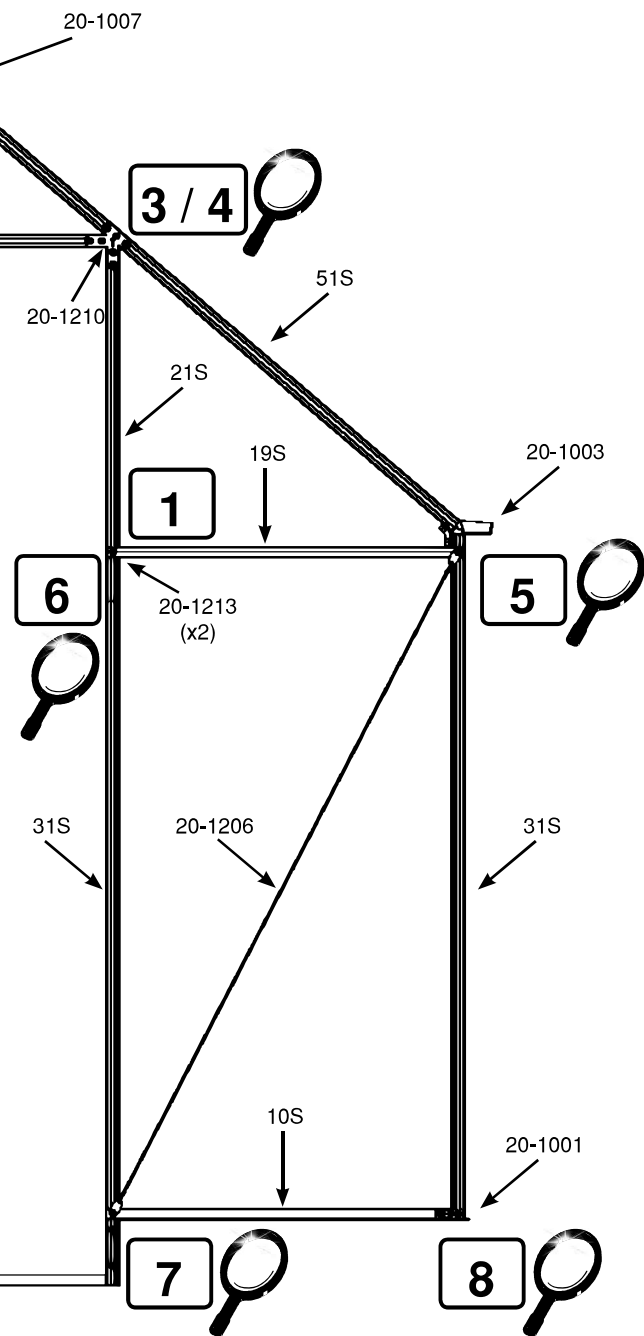

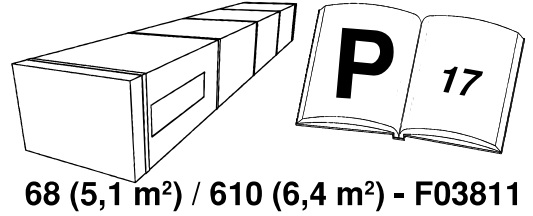
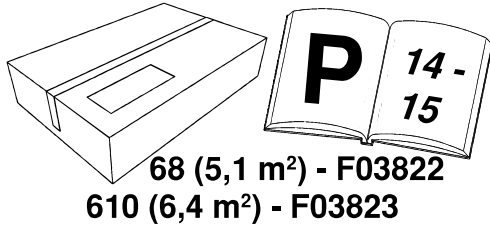

A & B	
66 (3,9 m ²)	0
68 (5,1 m ²)	x2
610 (6,4 m ²)	x1

B (x1)

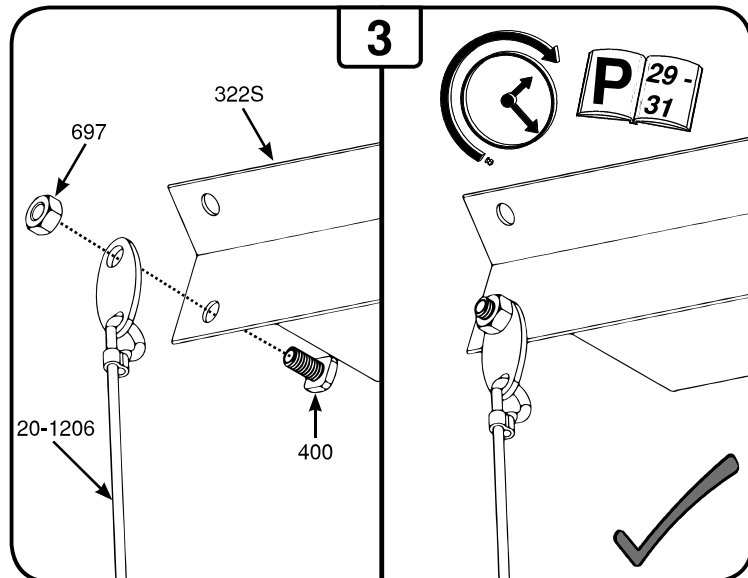
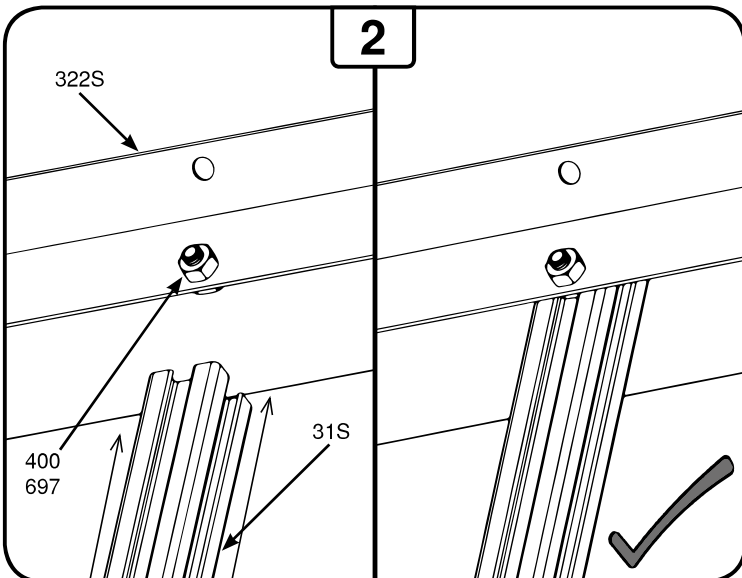
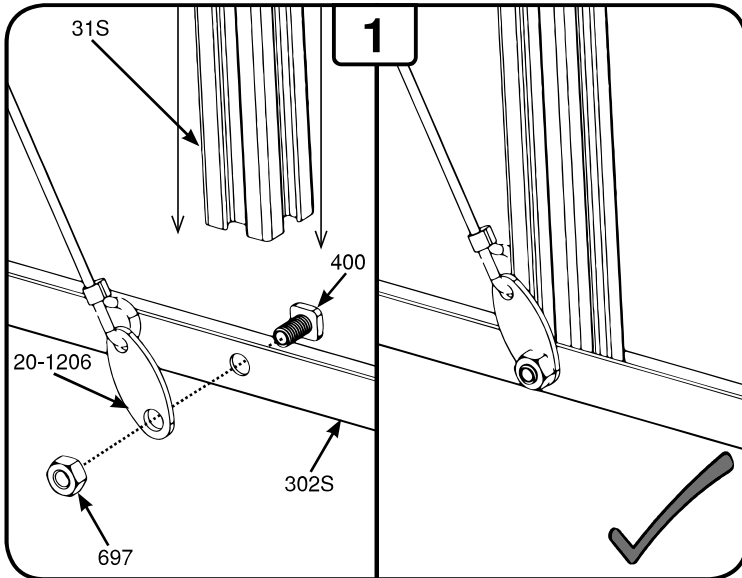
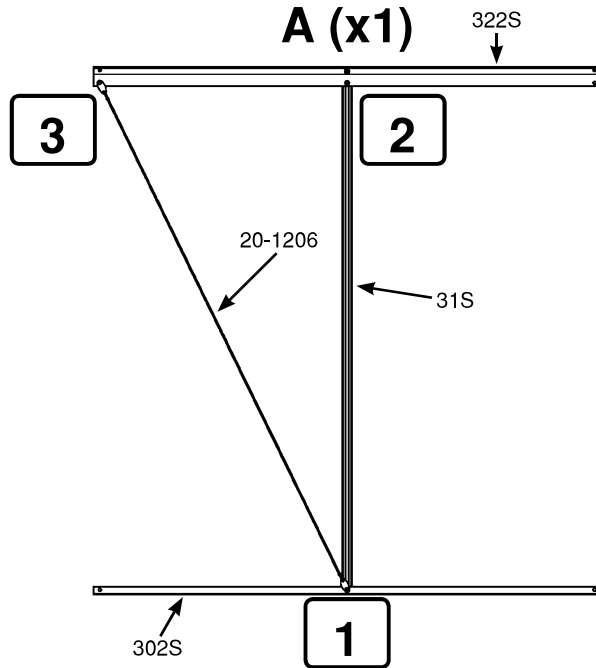
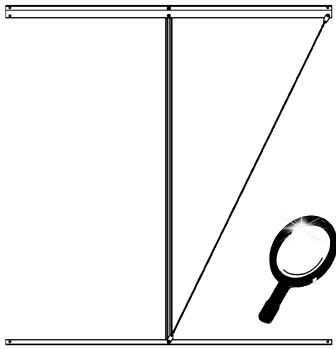

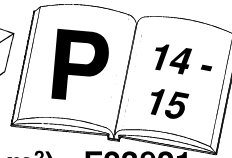
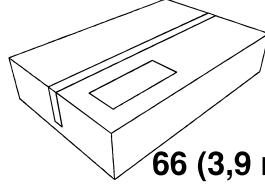
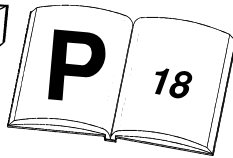
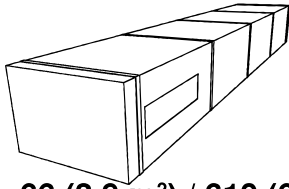

66 (3,9 m²) / 610 (6,4 m²) - F03812

66 (3,9 m²) - F03821
 610 (6,4 m²) - F03823



A (x1)

323S

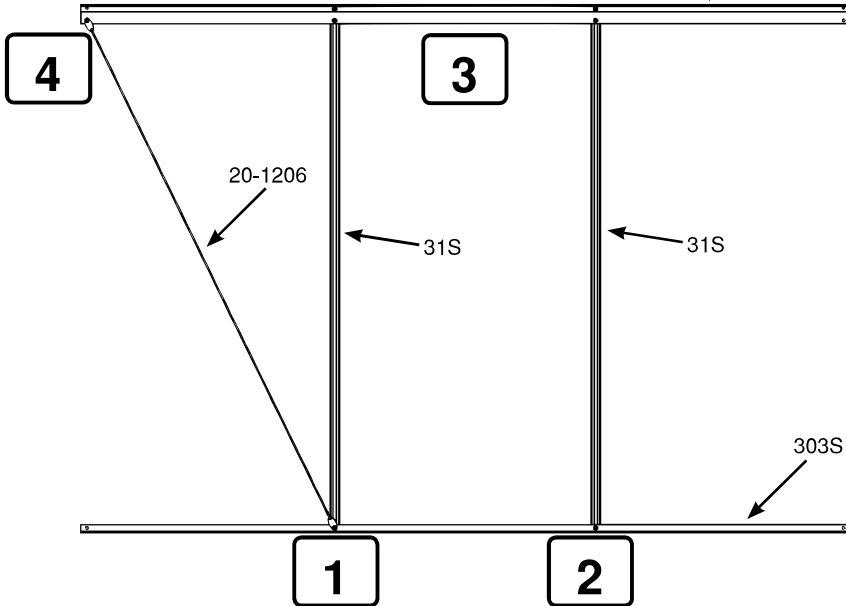

A & B	
66 (3,9 m ²)	x1
68 (5,1 m ²)	0
610 (6,4 m ²)	x1

B (x1)

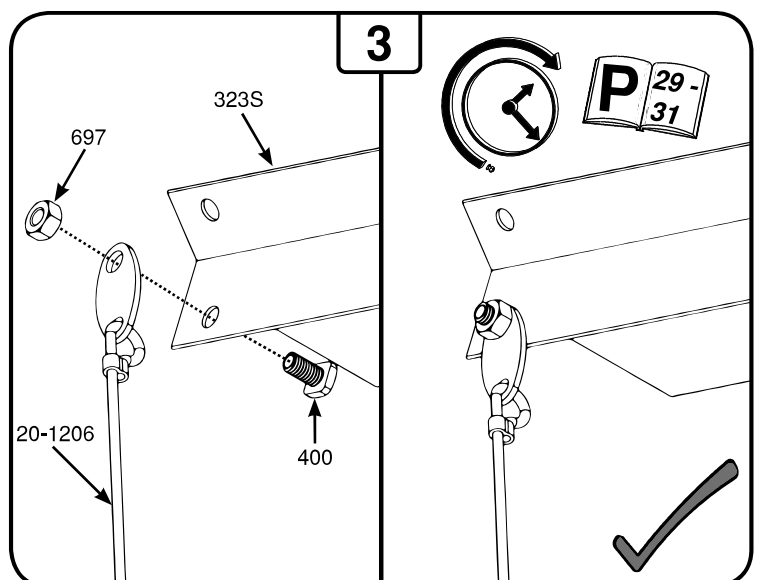
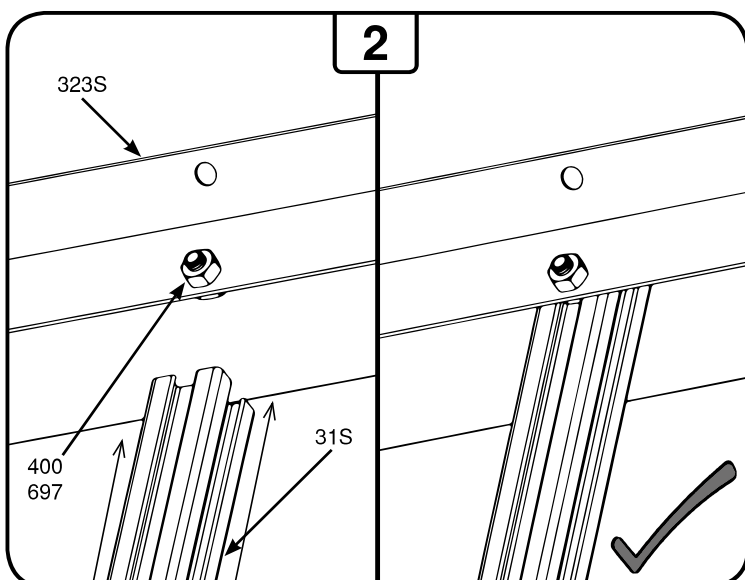
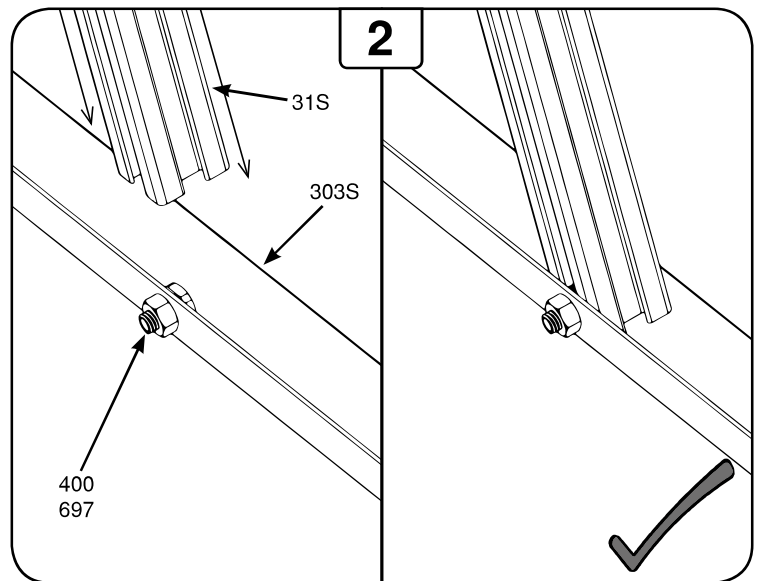
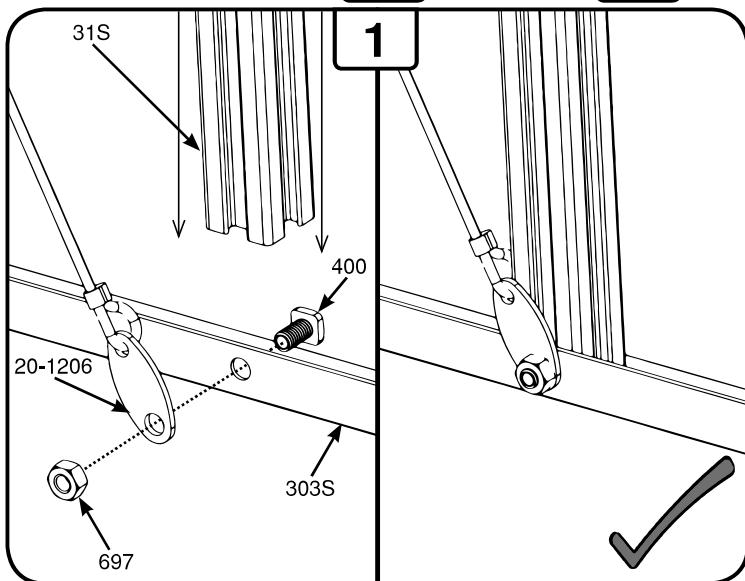
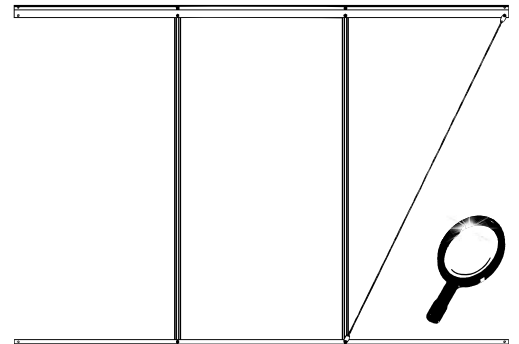

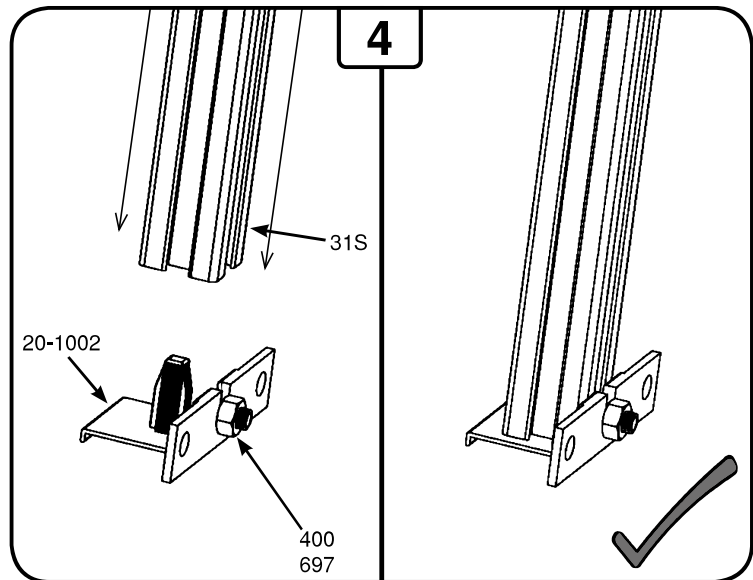
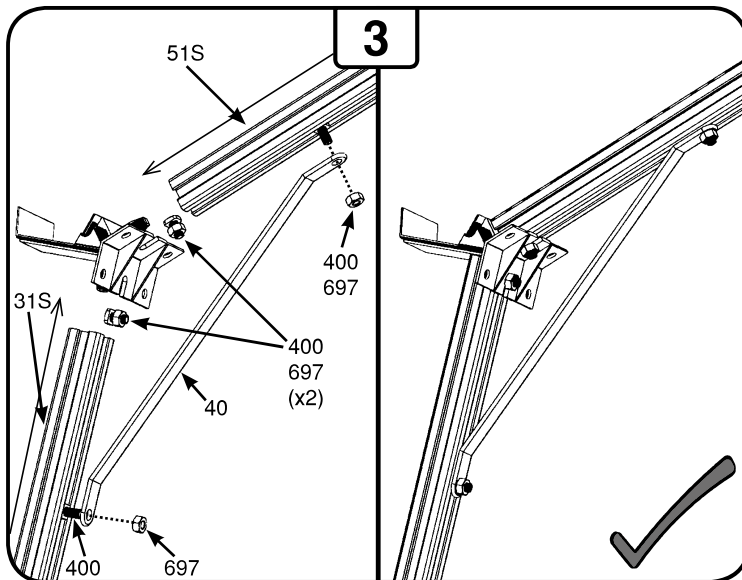
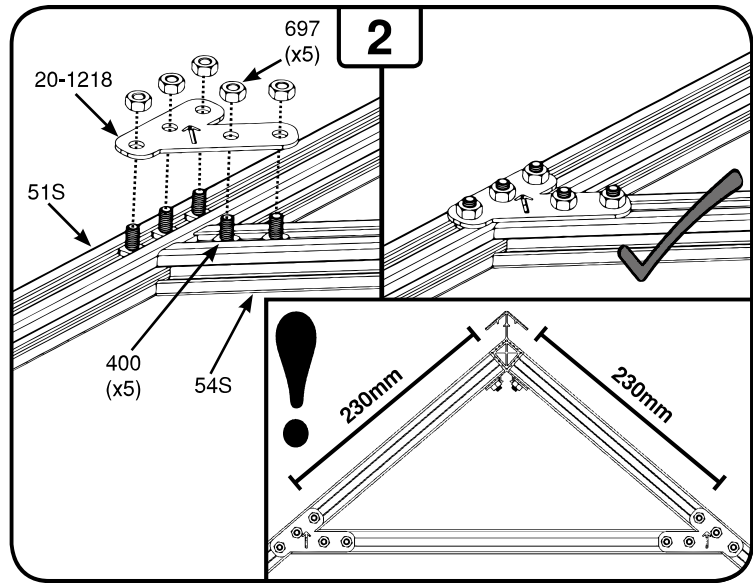
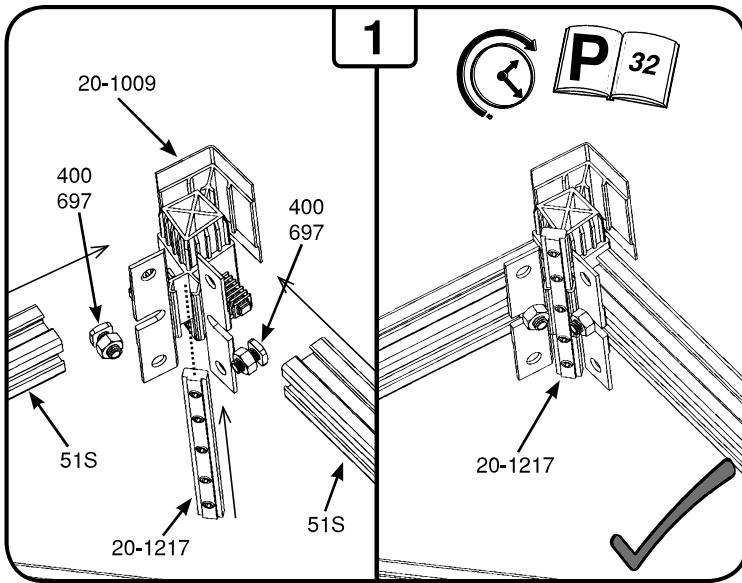
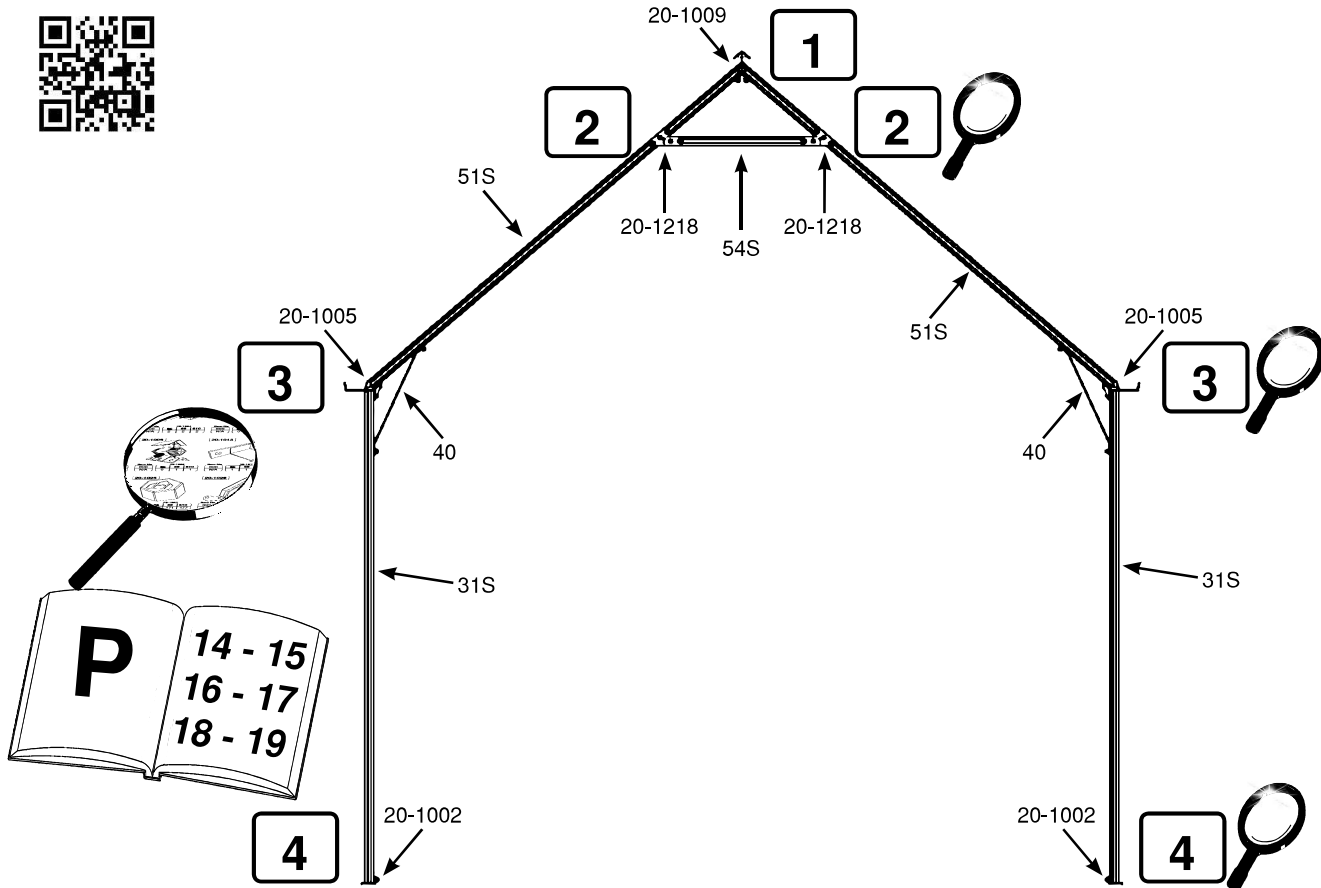

66

3,9 m²

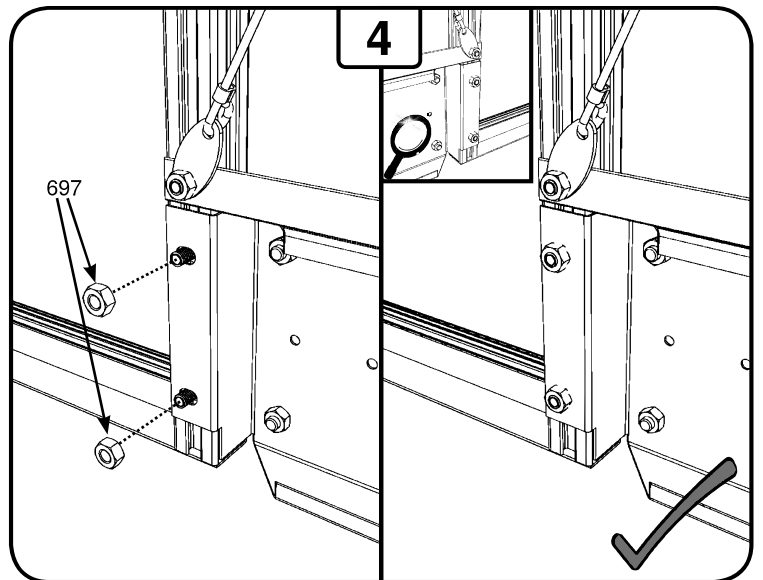
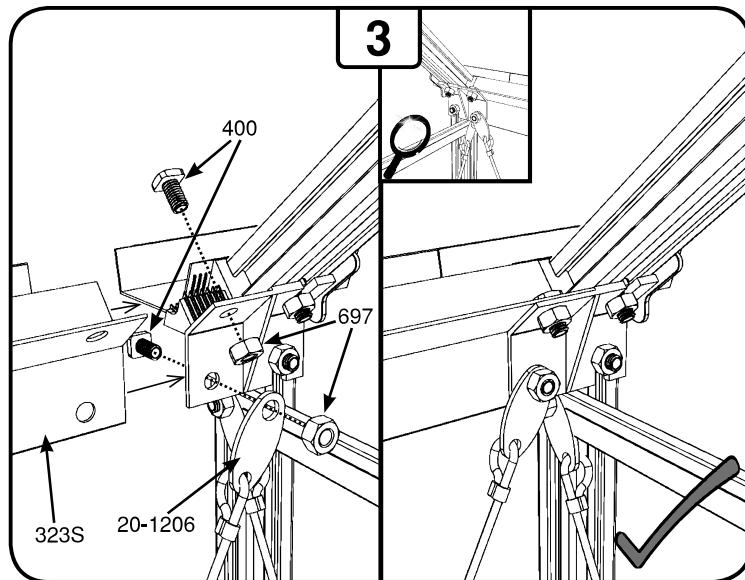
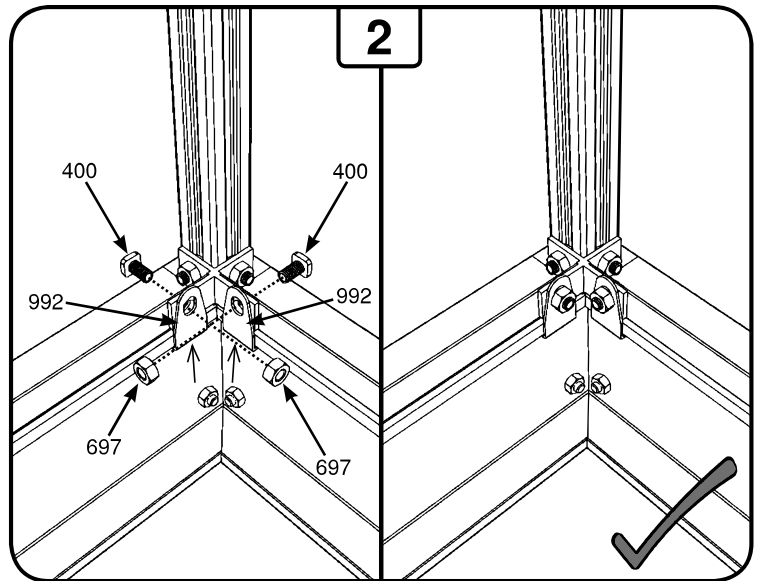
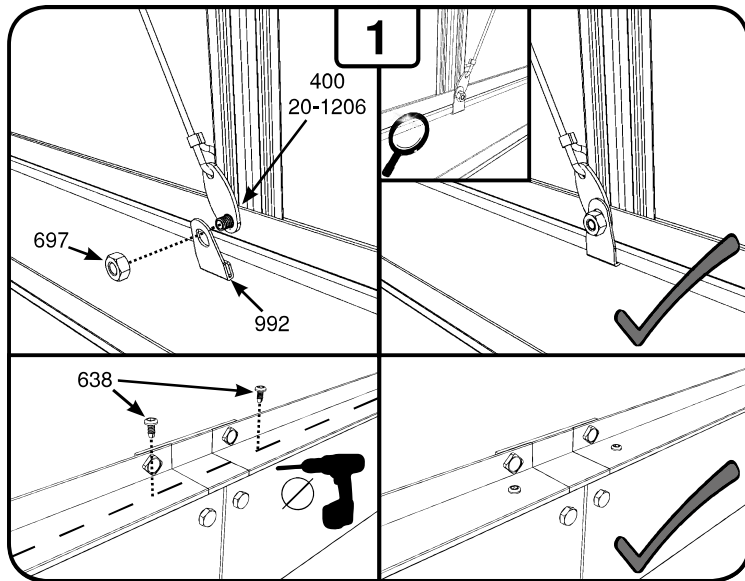
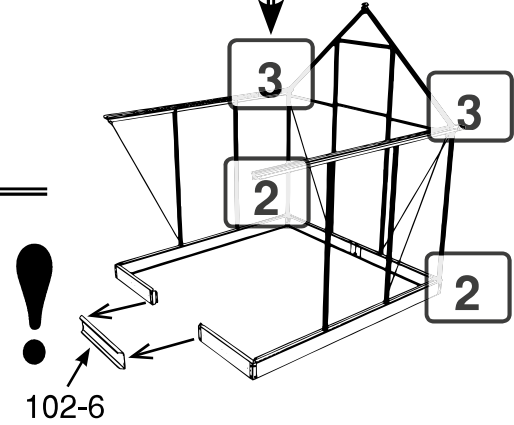
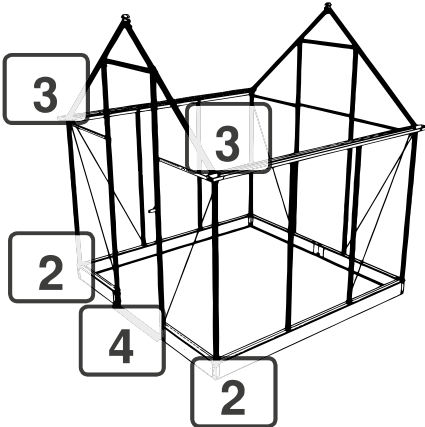
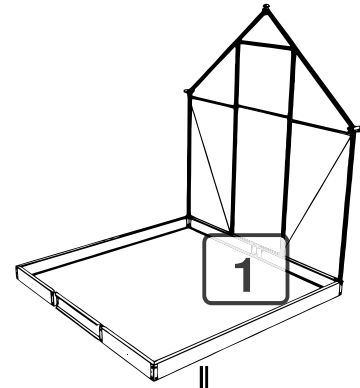

68

5,1 m²

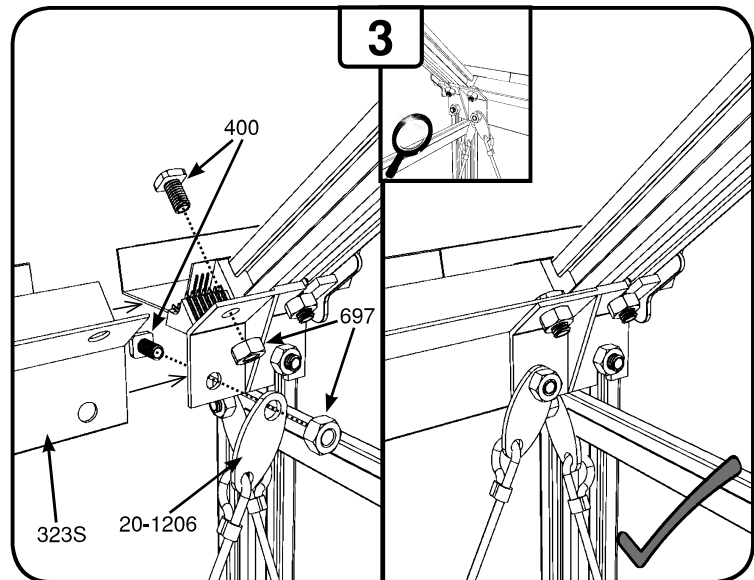
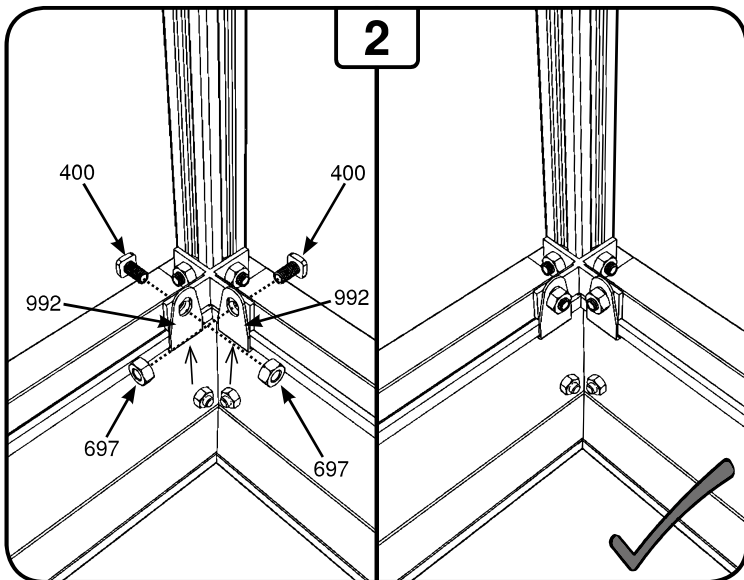
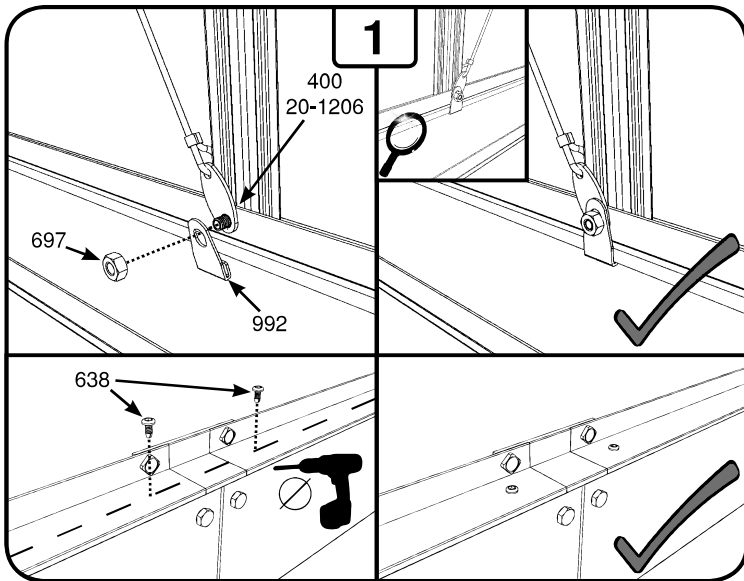
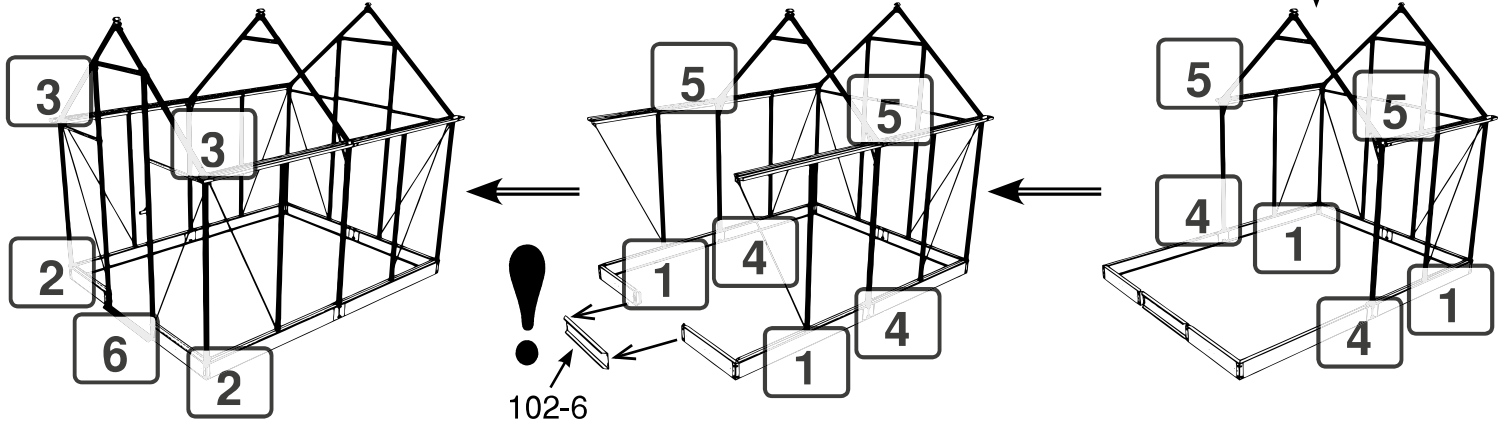
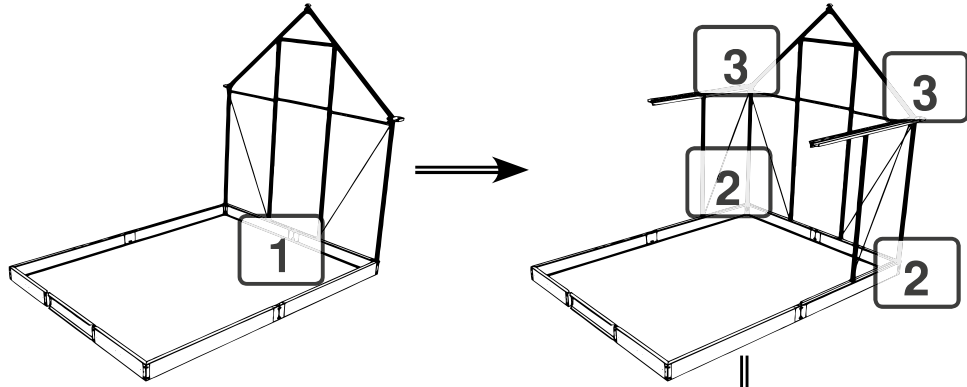
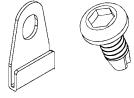

610
6,4 m²

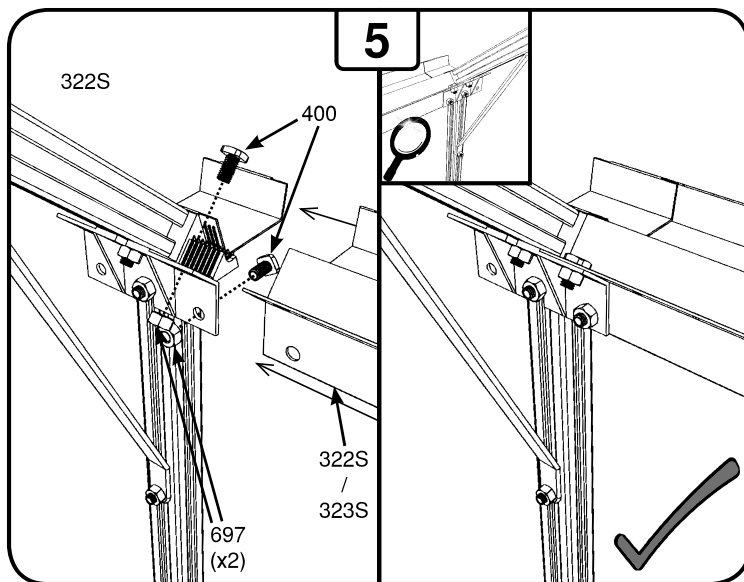
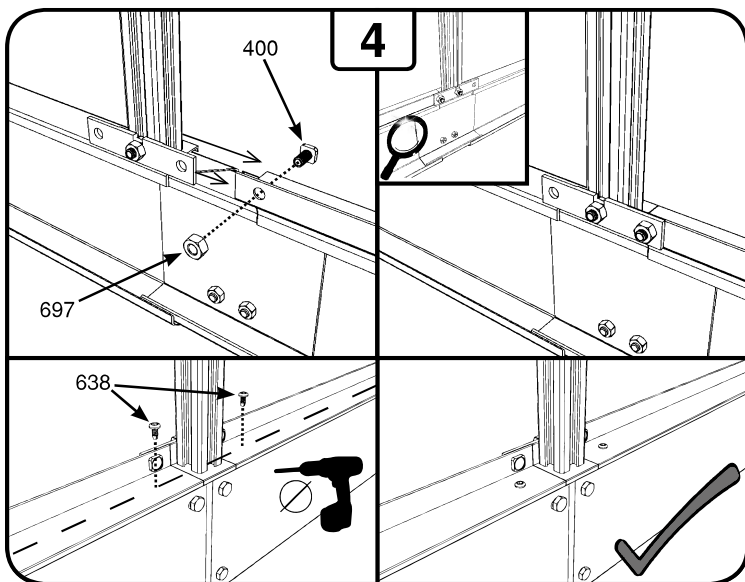
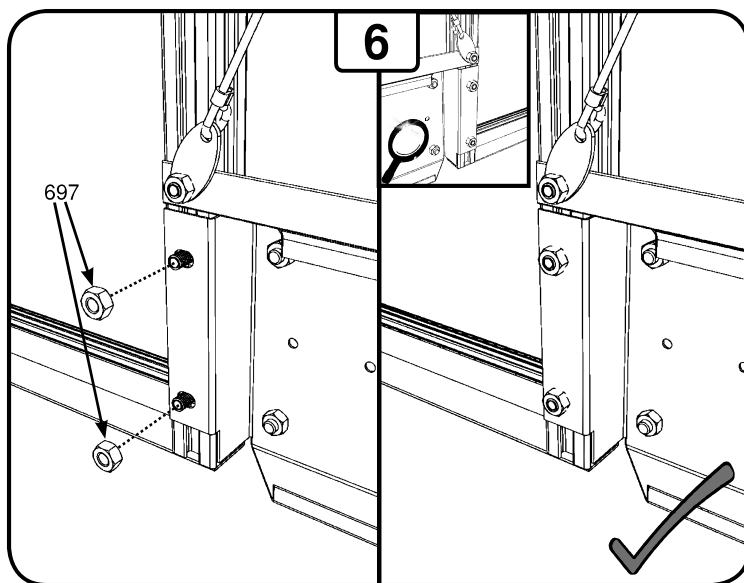
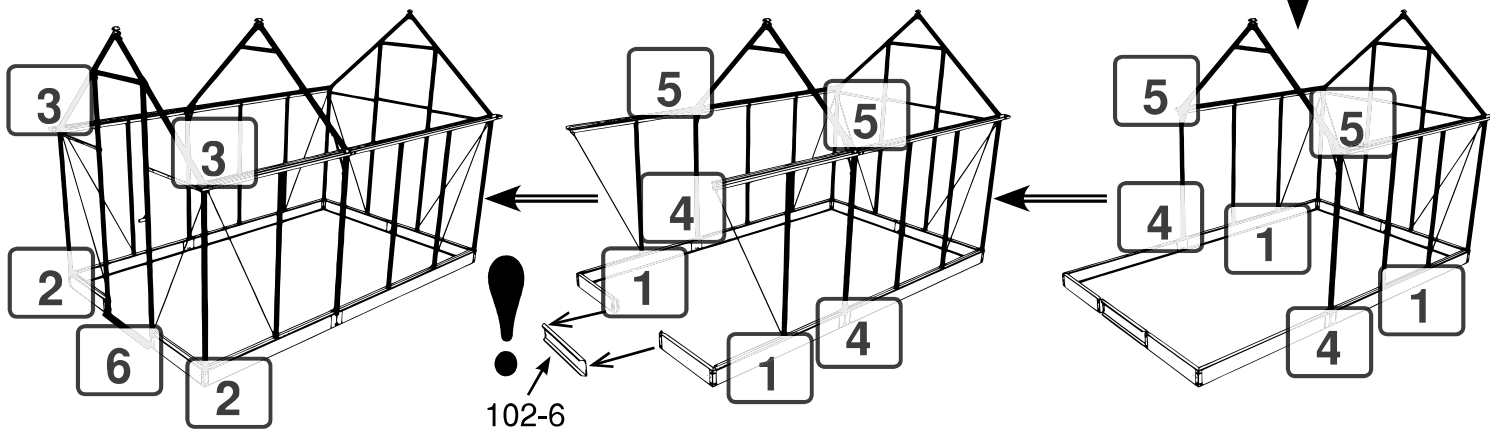
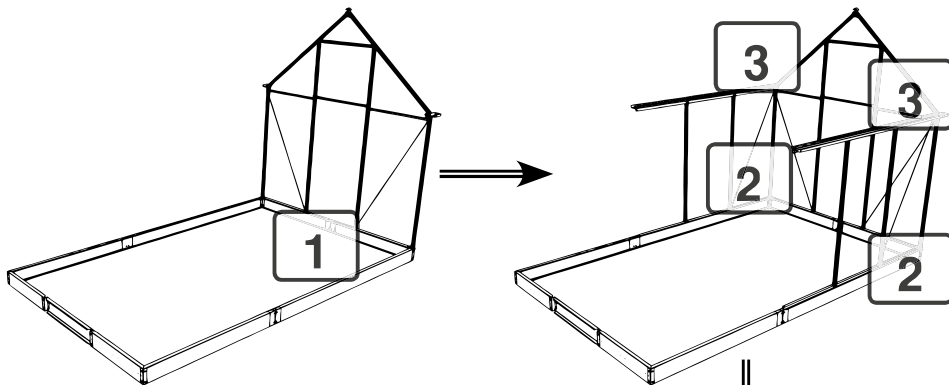
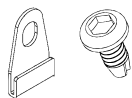

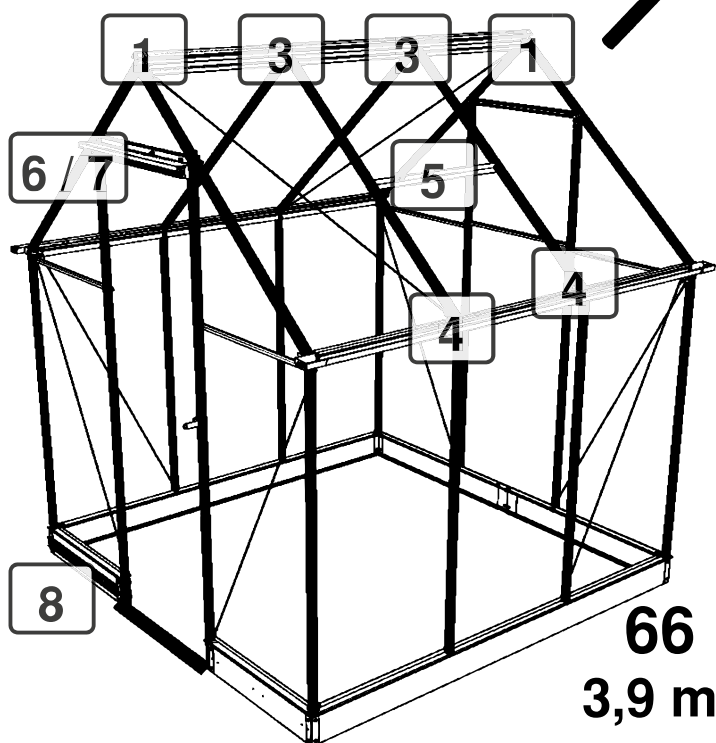
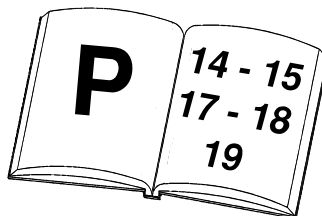

66
3,9 m²

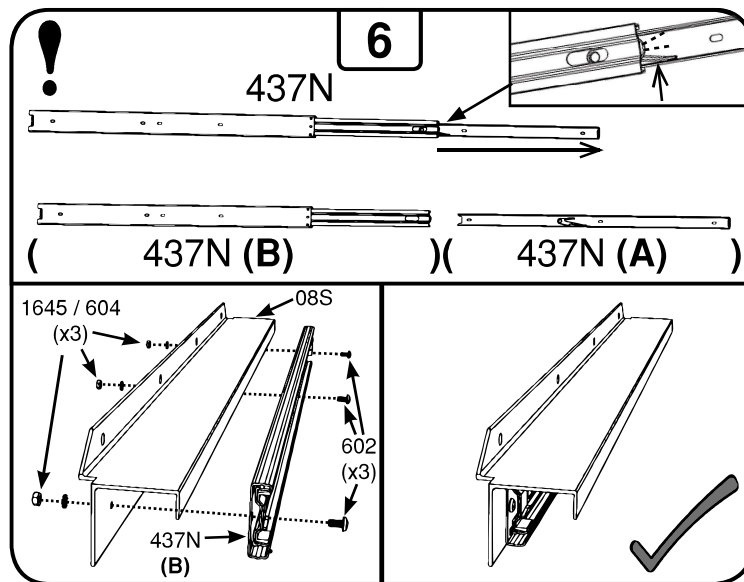
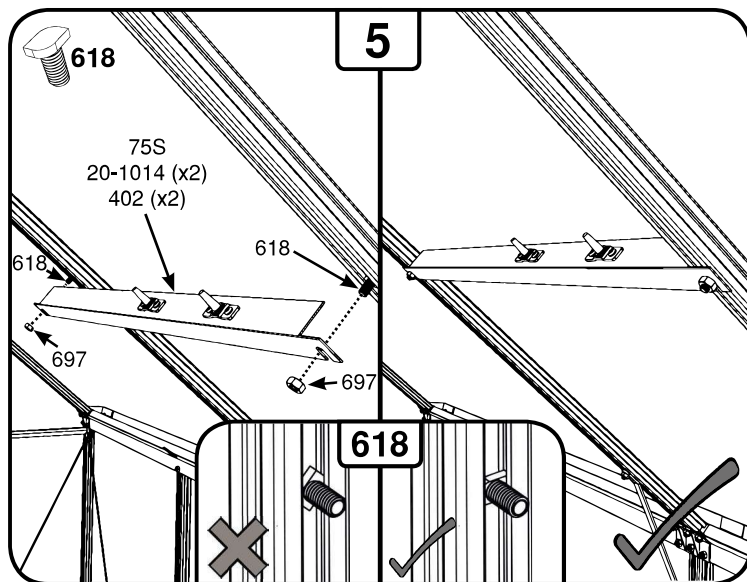
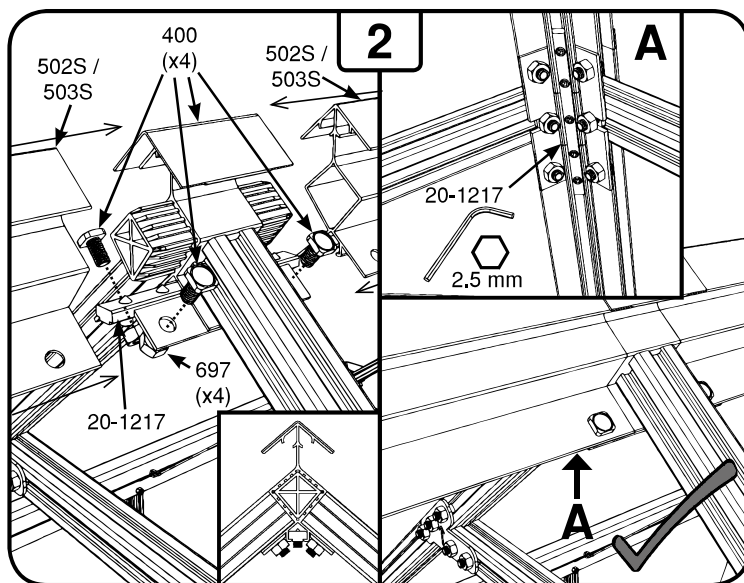
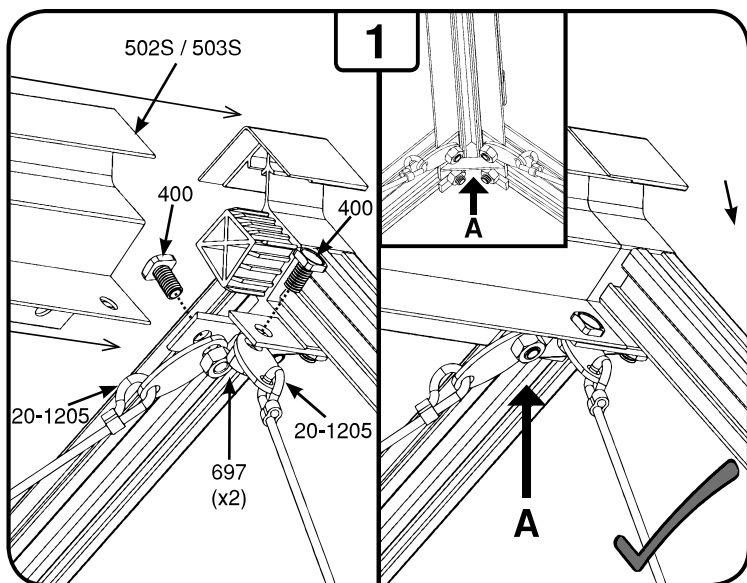
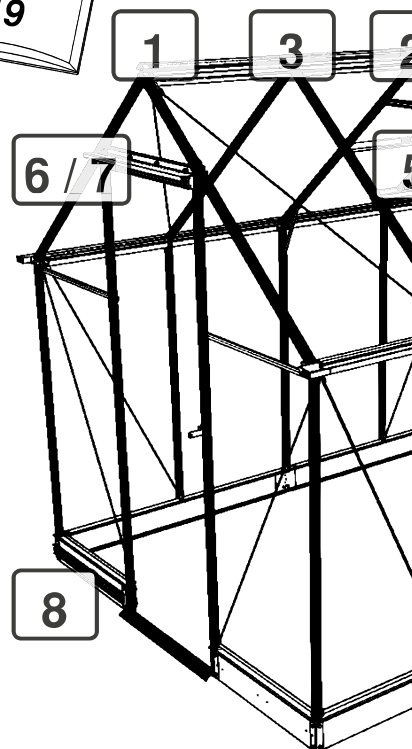

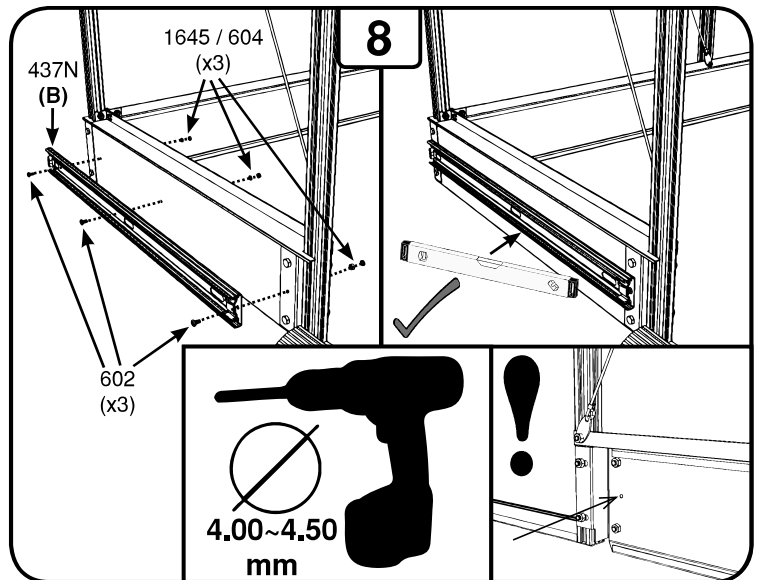
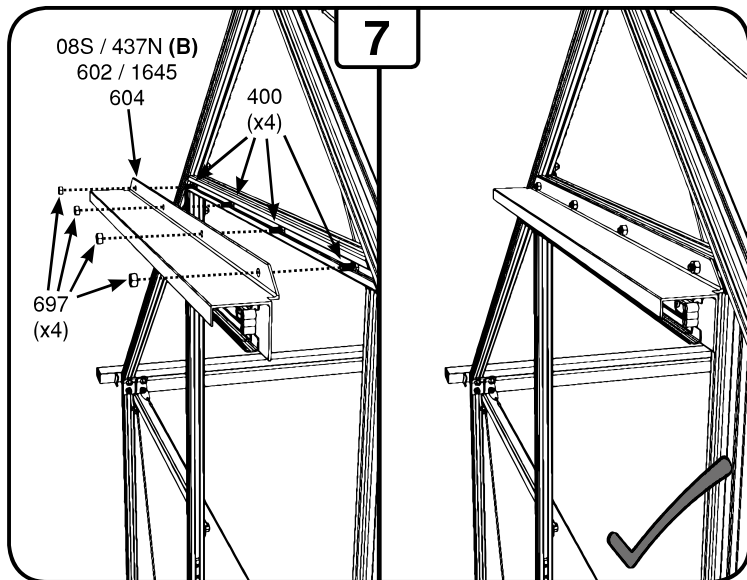
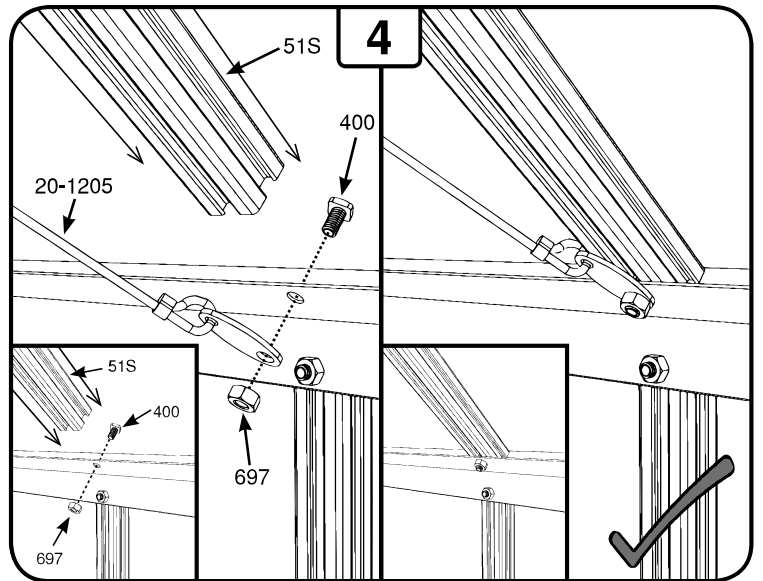
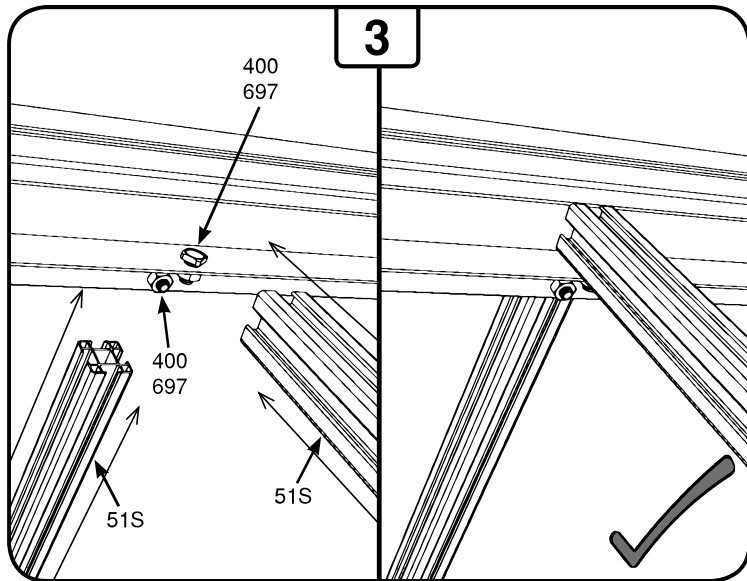
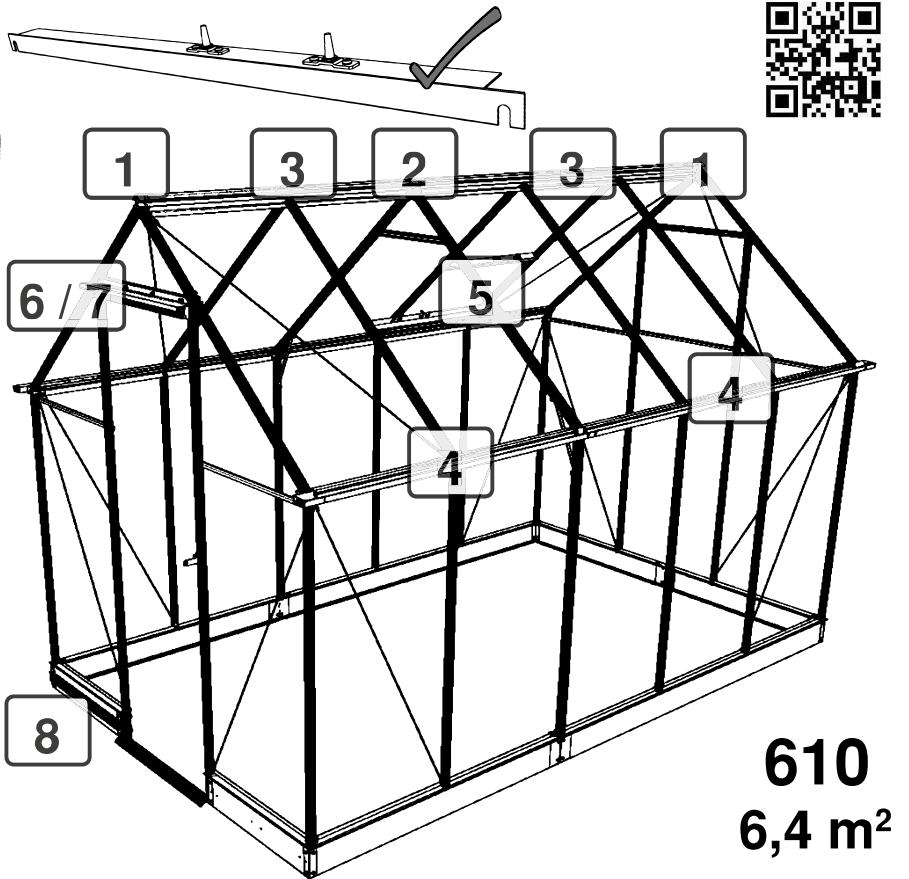
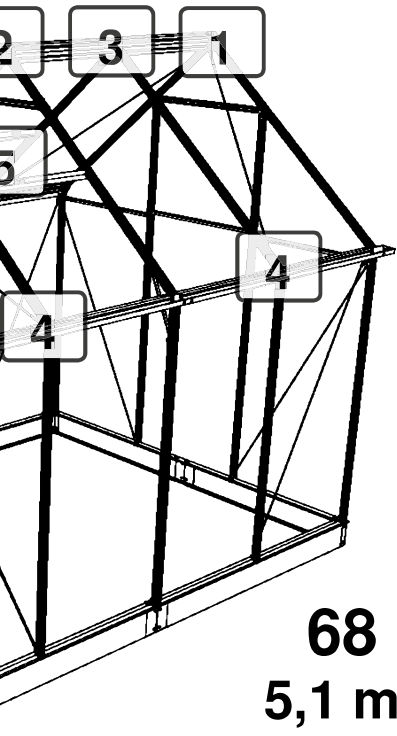
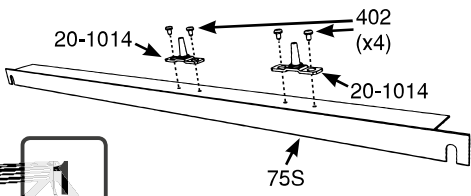

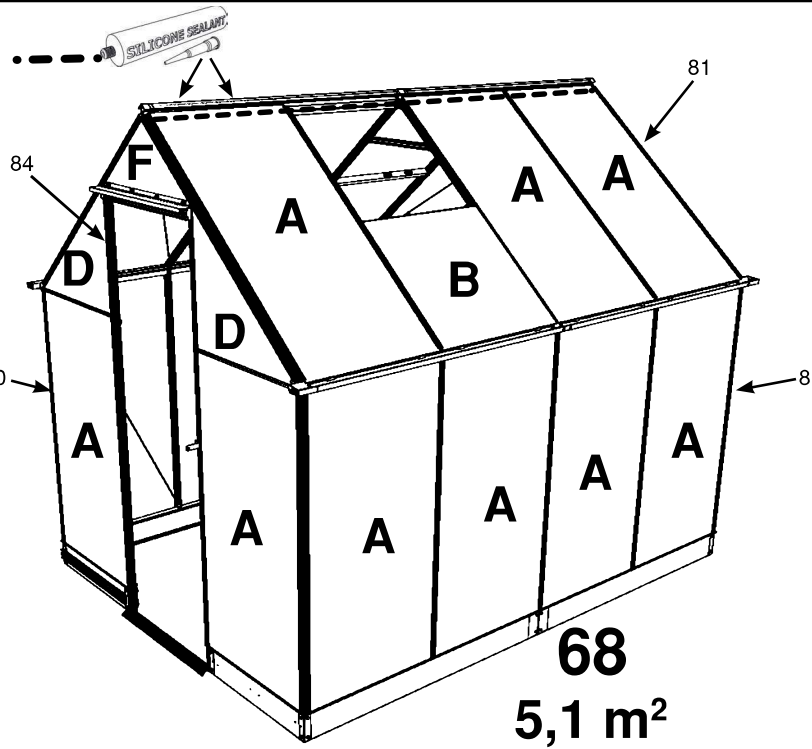
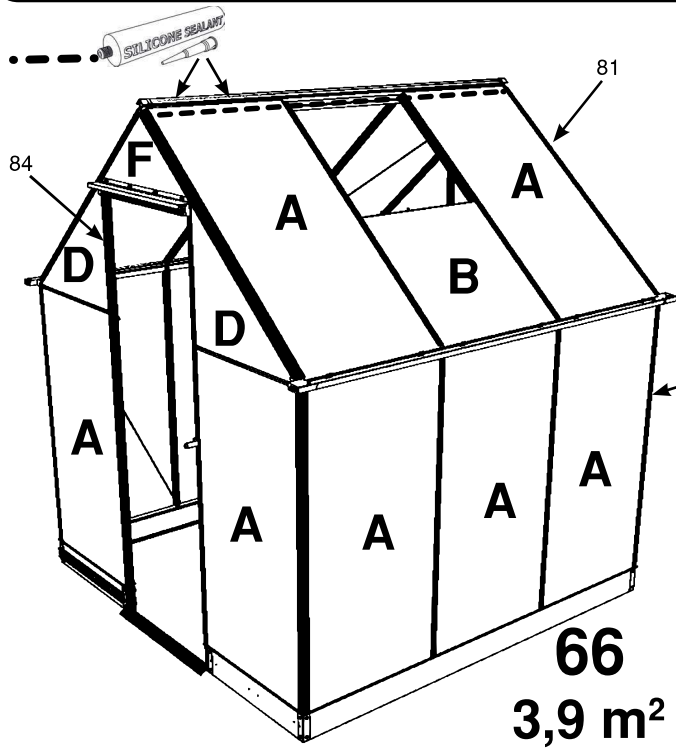

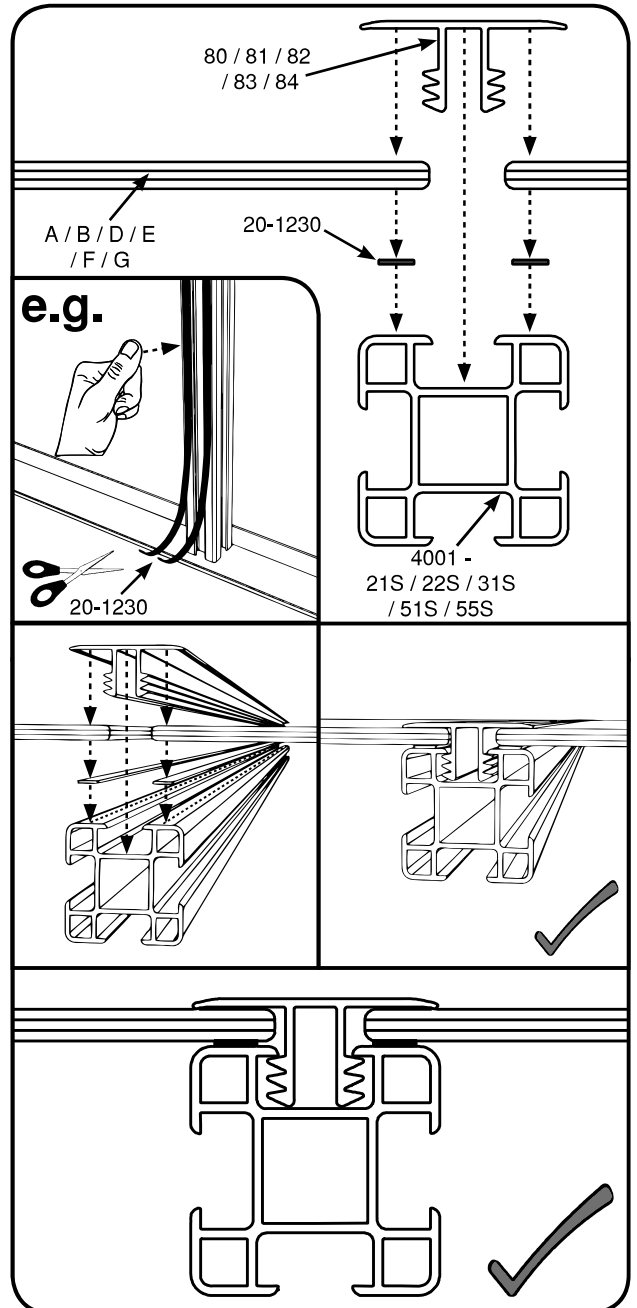

	#	66 3,9 m ²	68 5,1 m ²	610 6,4 m ²	Item No:
	80 (1225 mm)	18	20	22	7093080
	81 (1202 mm)	12	14	16	7093081
	82 (512 mm)	4	4	4	7093082
	20-1030 (595 mm)	1	1	1	20-1030
	20-1024	1	1	1	20-1024
	20-1230 (22000 mm)	3	4	4	20-1230
	350	1	1	1	00300350

	mm	66 3,9 m ²	68 5,1 m ²	610 6,4 m ²	Item No:
A	610 x 1222	17	20	24	00281600
B	610 x 608	1	2	2	00281601
C	599 x 610	1	2	2	00281602
D	610 x 516 x 19 x 11	4	4	4	00281603
E	610 x 540 x 800 x 540	1	1	1	00281604
F	610 x 5 x 265 x 5	1	1	1	00281605
G	610 x 454	1	1	1	00281606

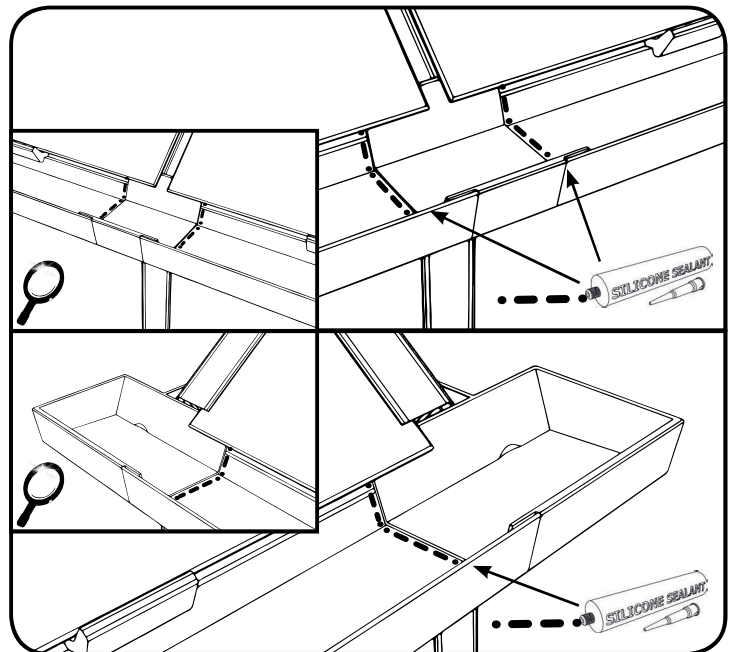
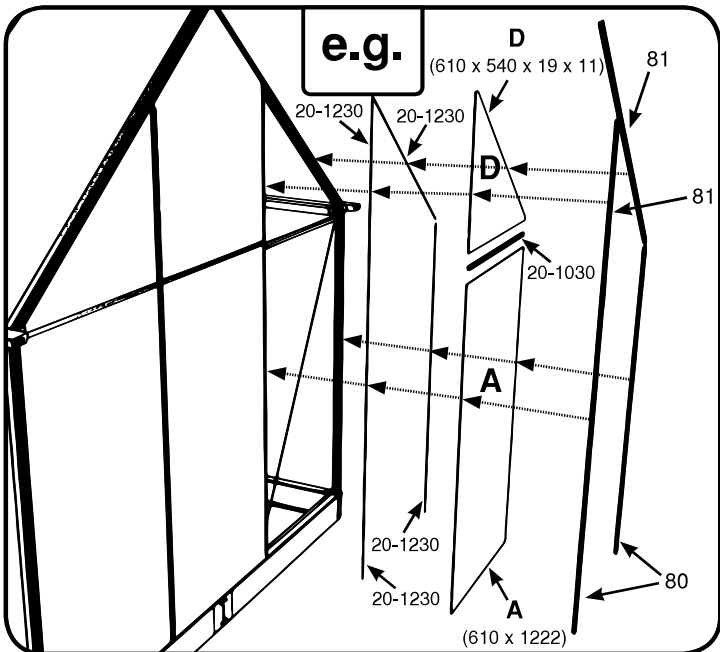
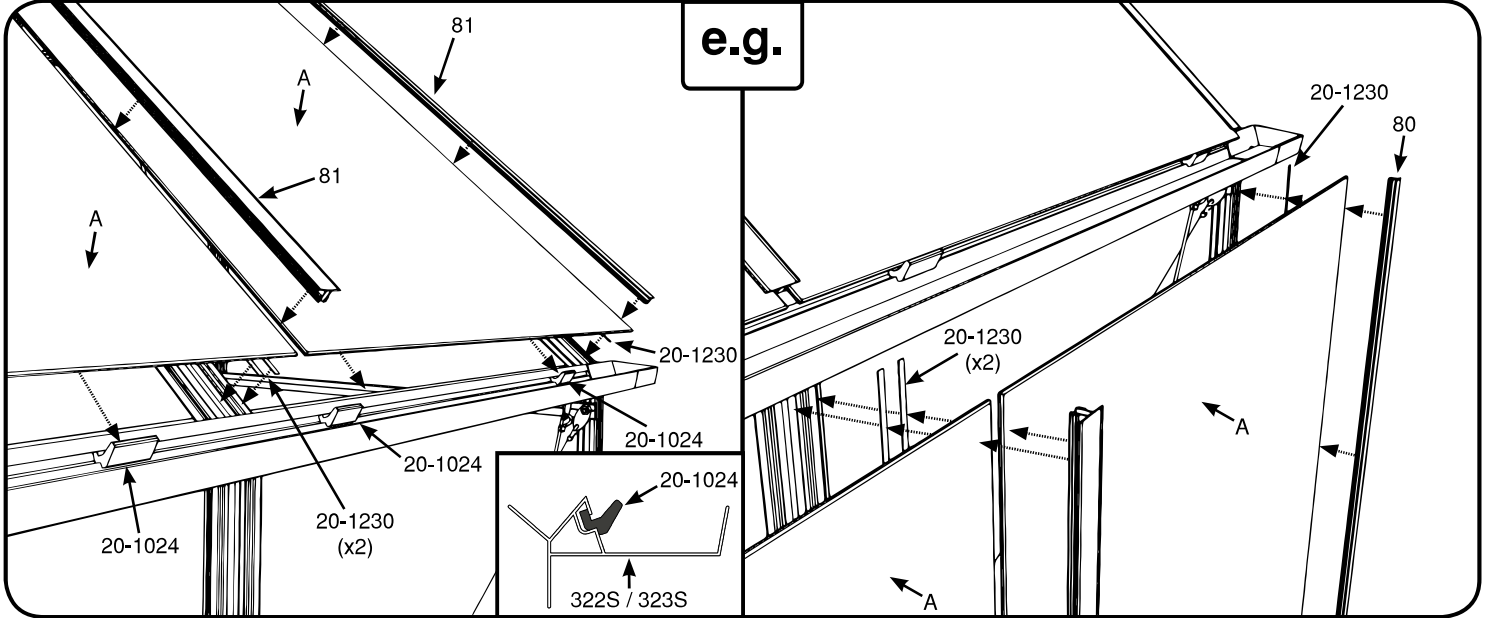
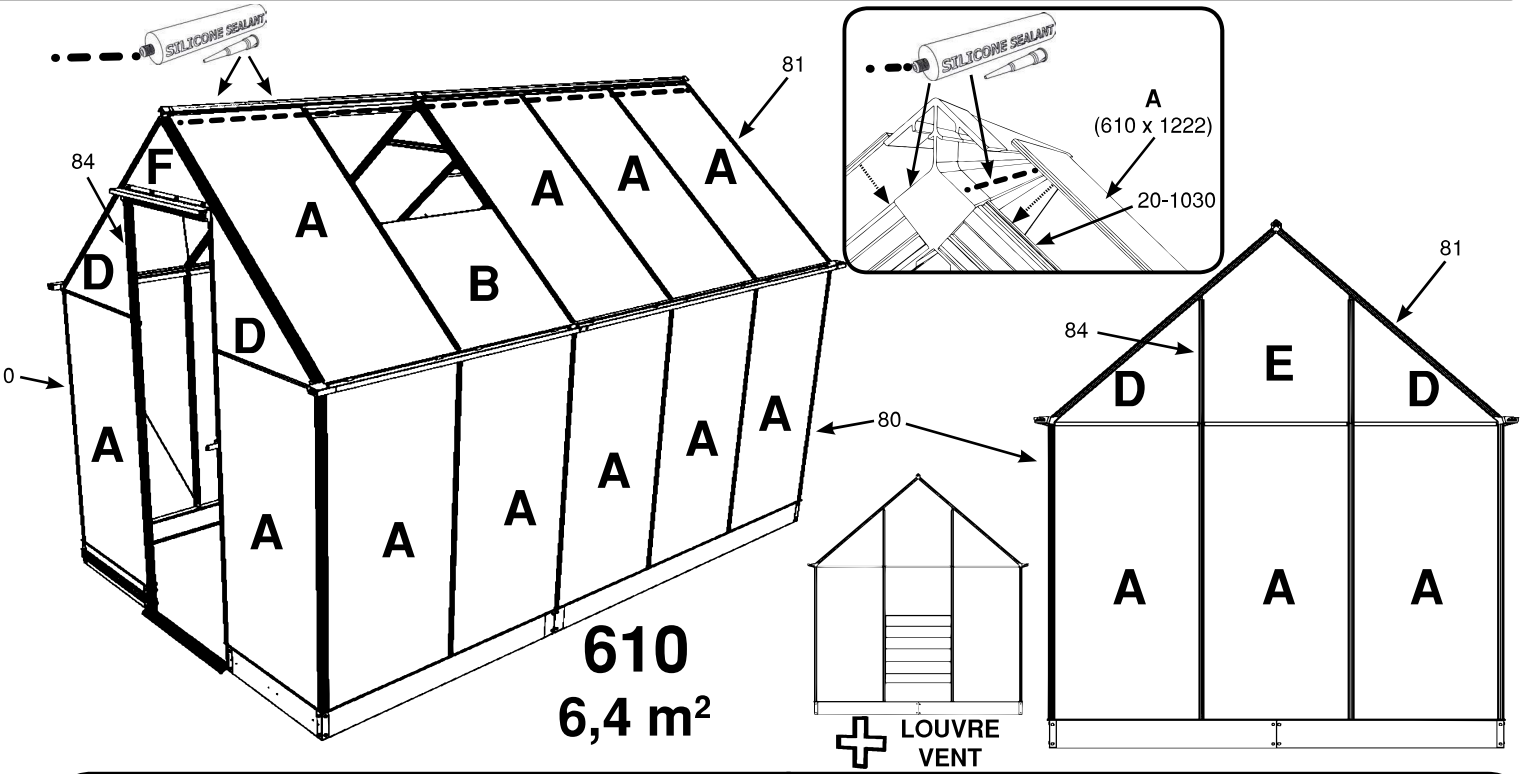

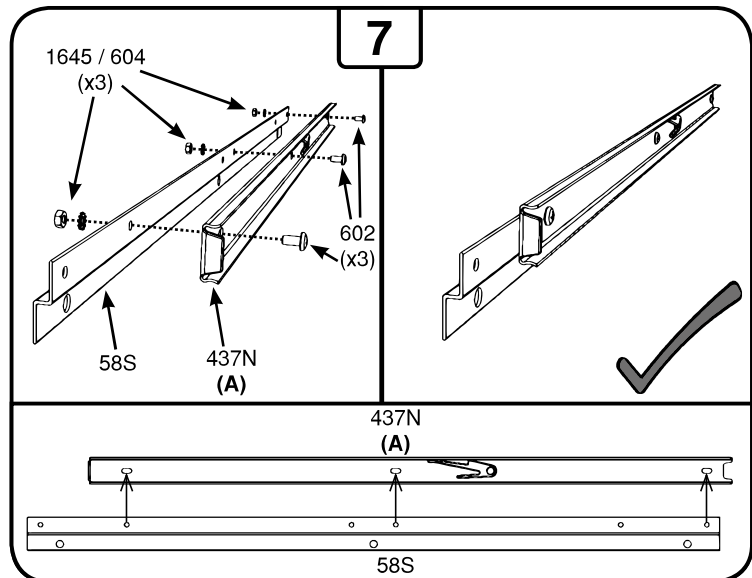
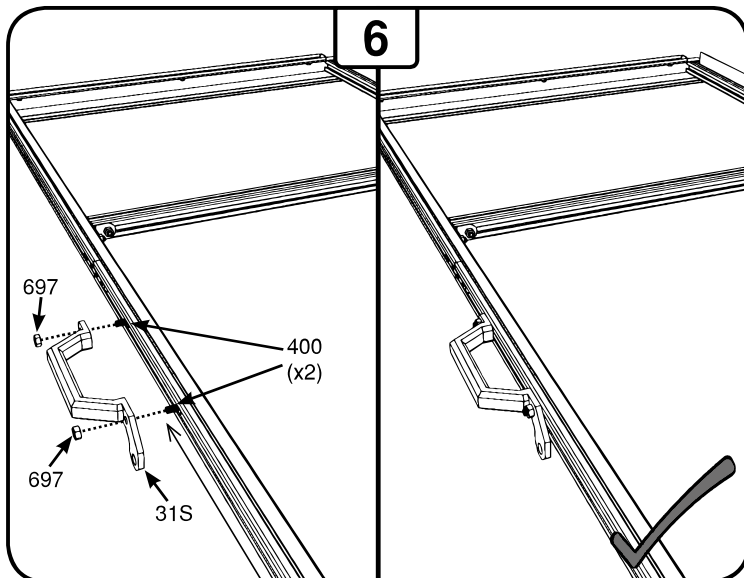
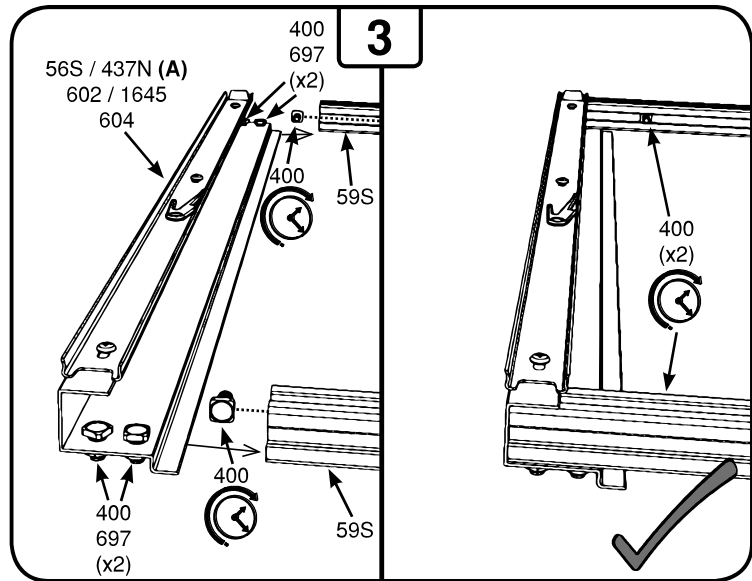
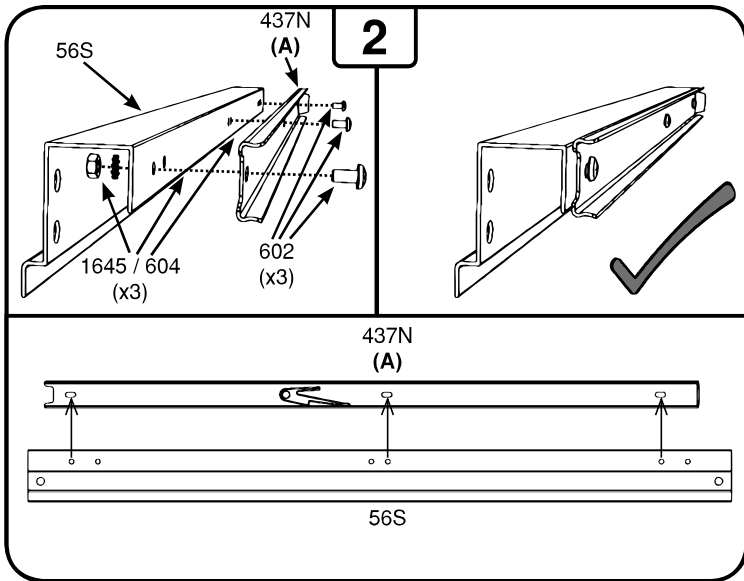
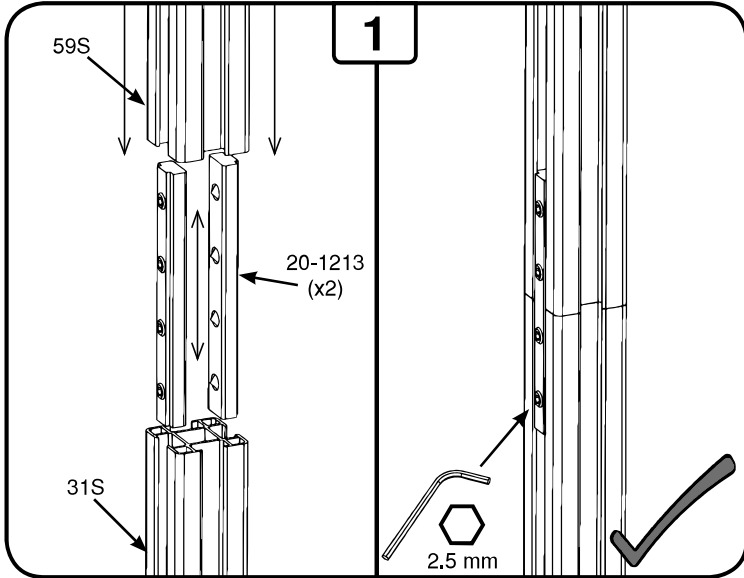
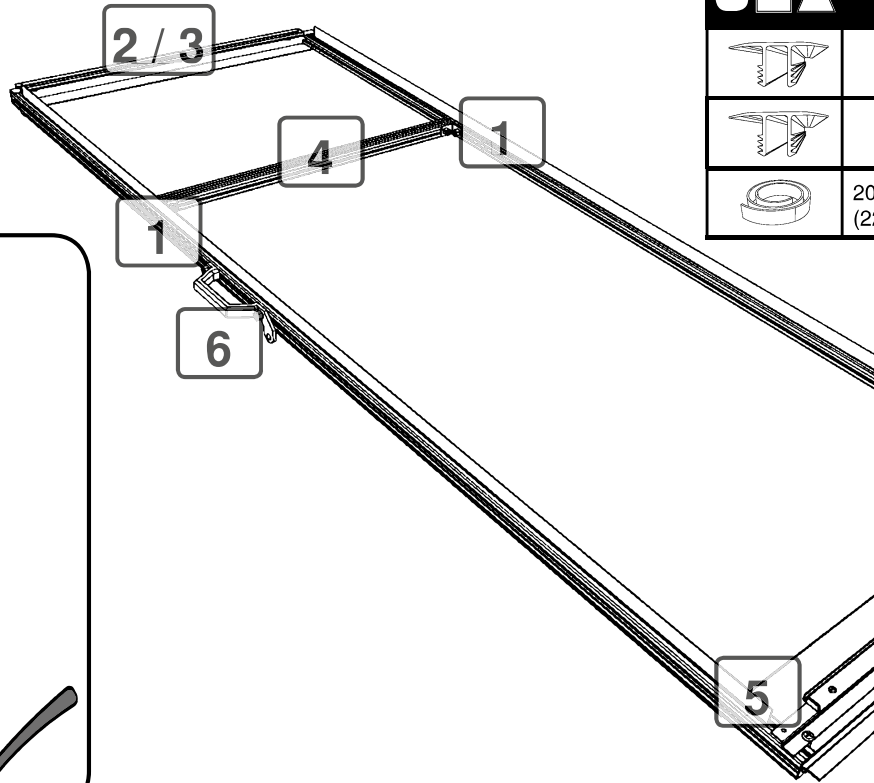
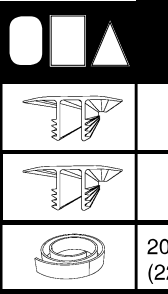
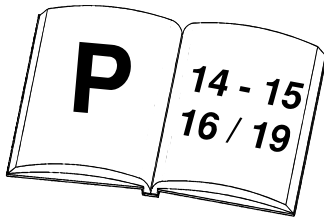



#	66 3,9 m ²	68 5,1 m ²	610 6,4 m ²	Item No:
83 (450 mm)	2	2	2	7093083
84 (595 mm)	1	1	1	7093084
20-1230 (2000 mm) 	3	4	4	20-1230

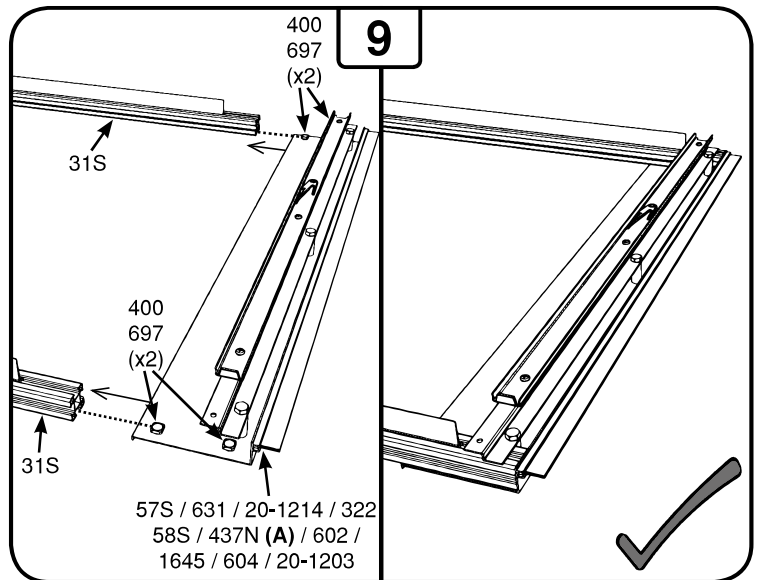
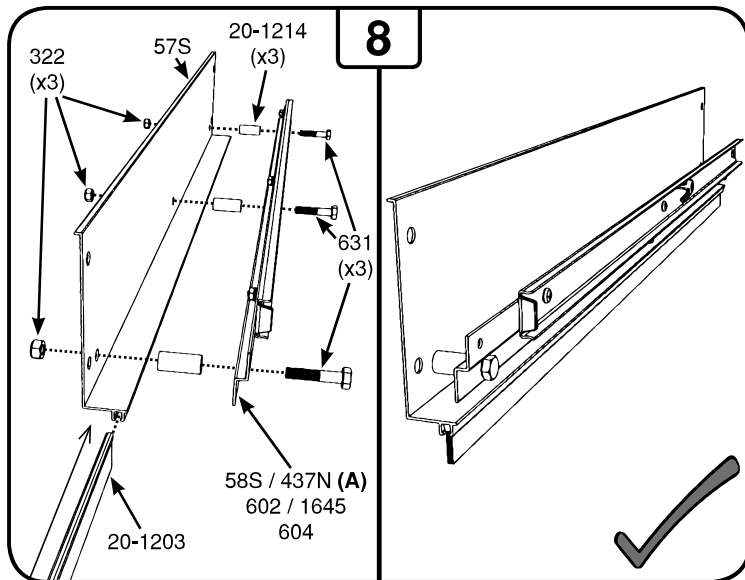
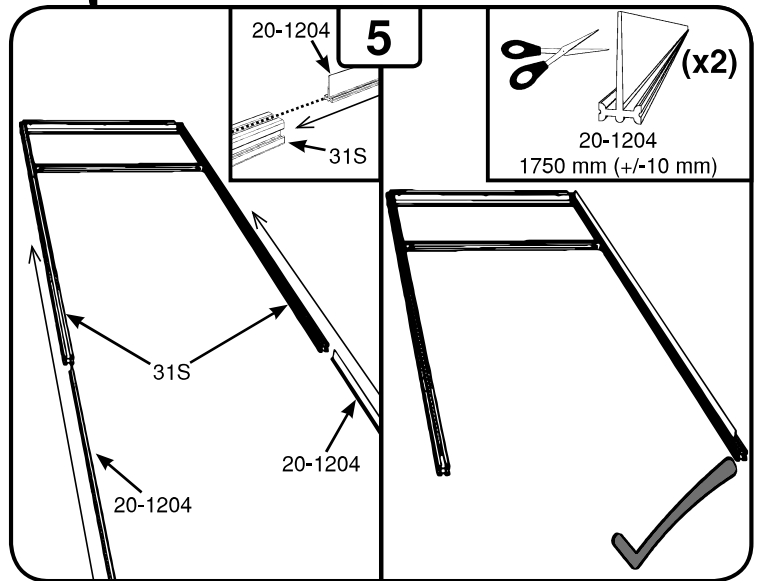
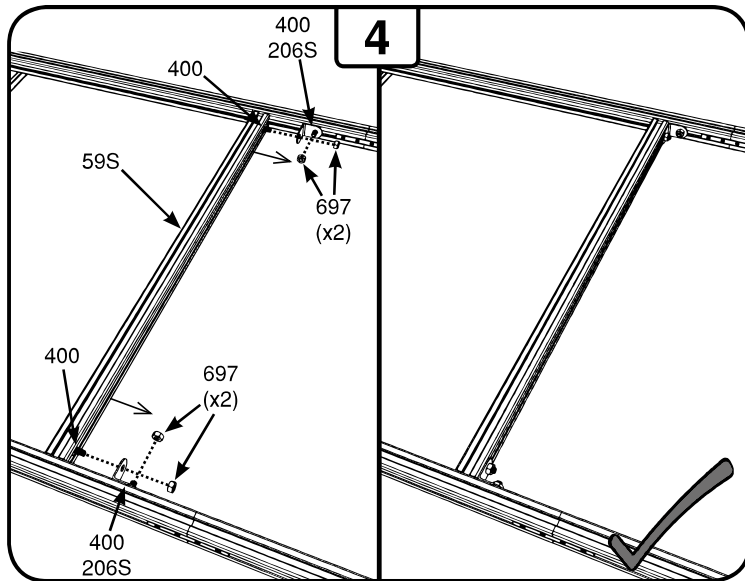
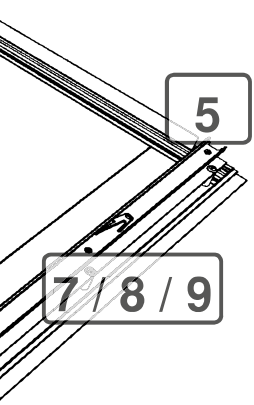
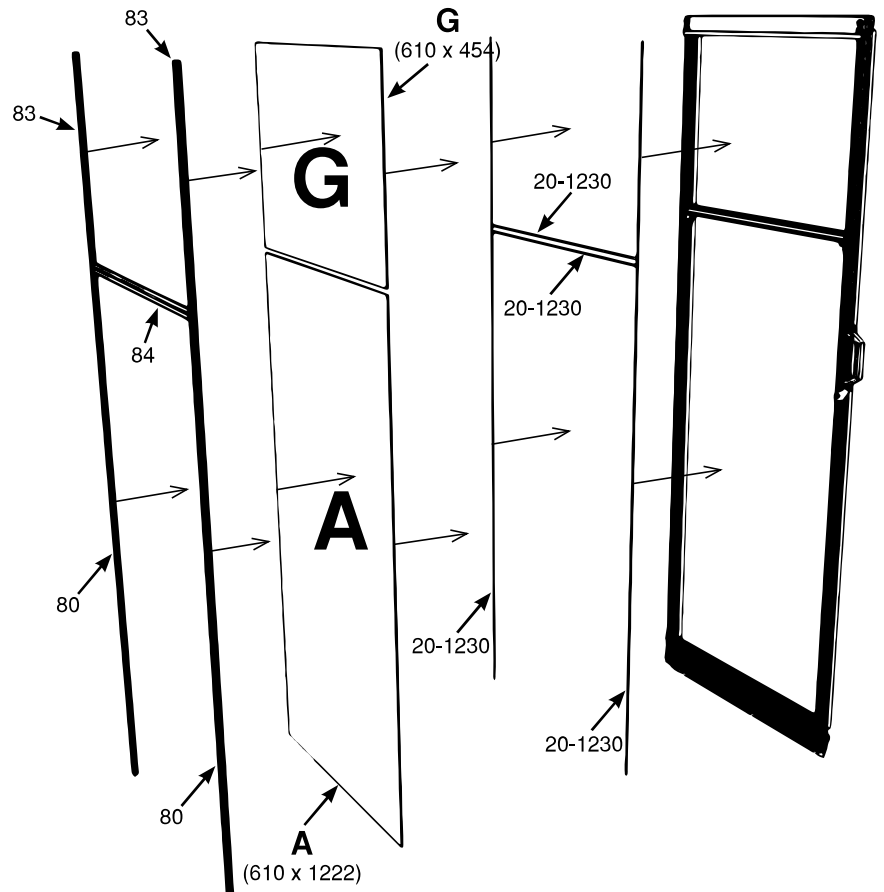

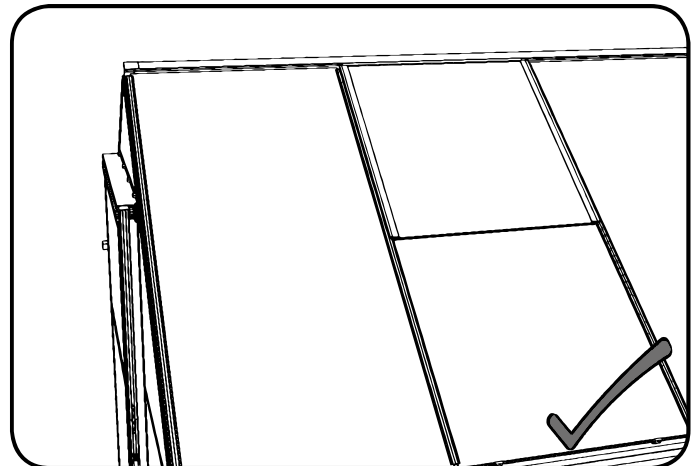
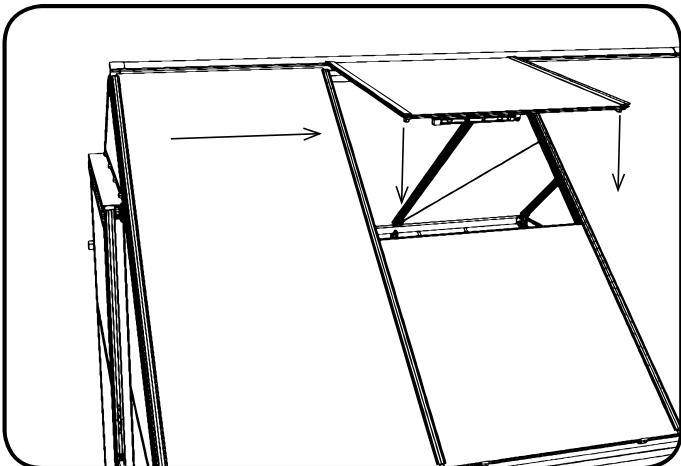
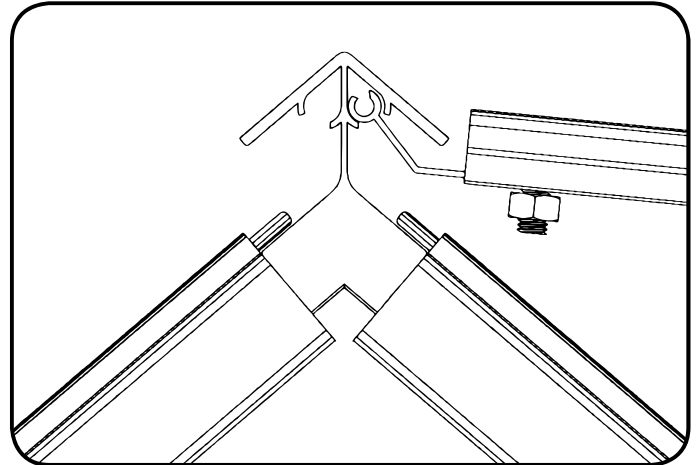
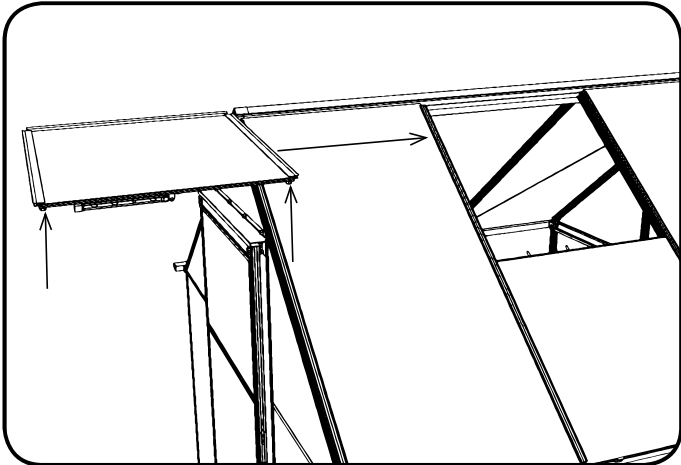
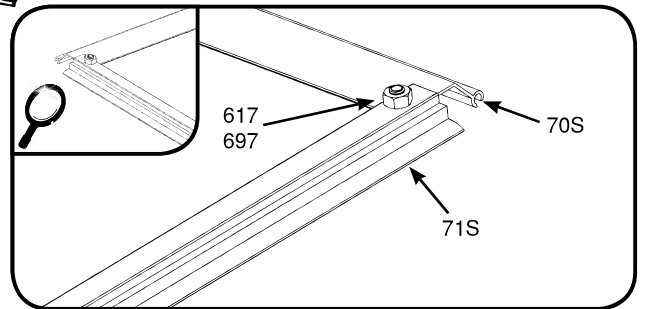
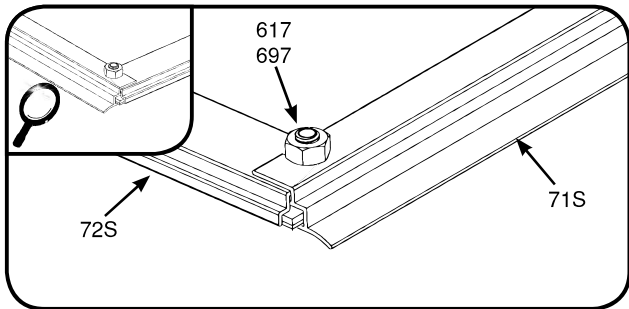
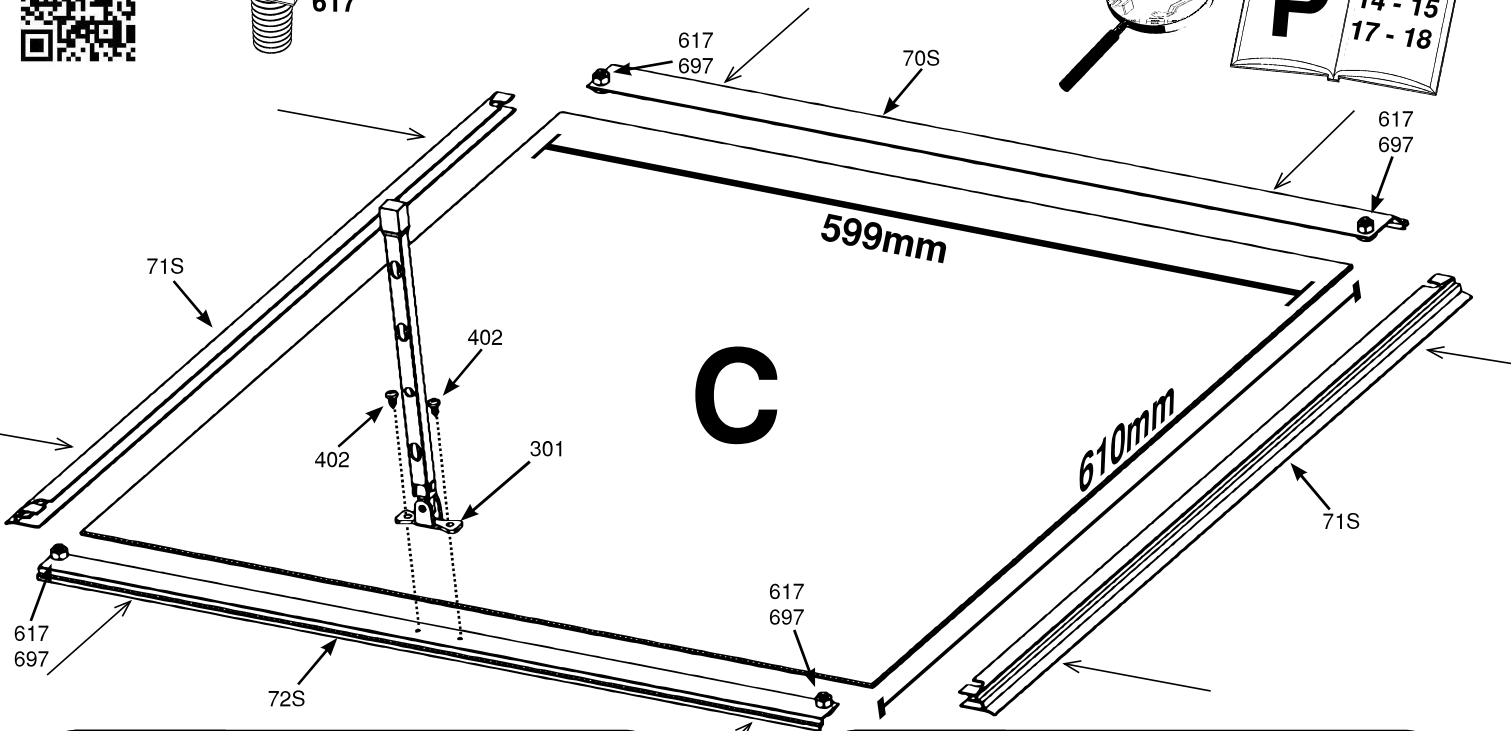
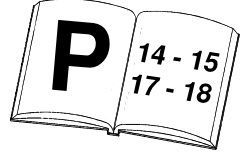

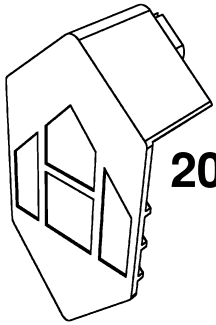
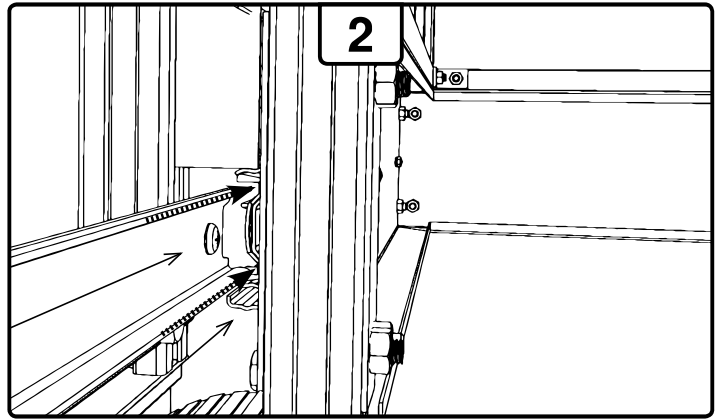
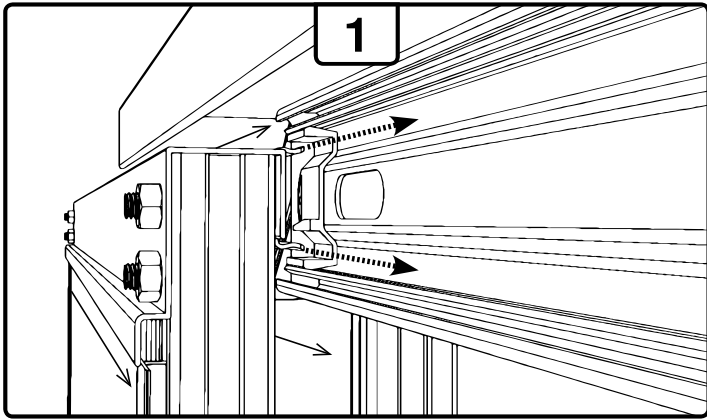
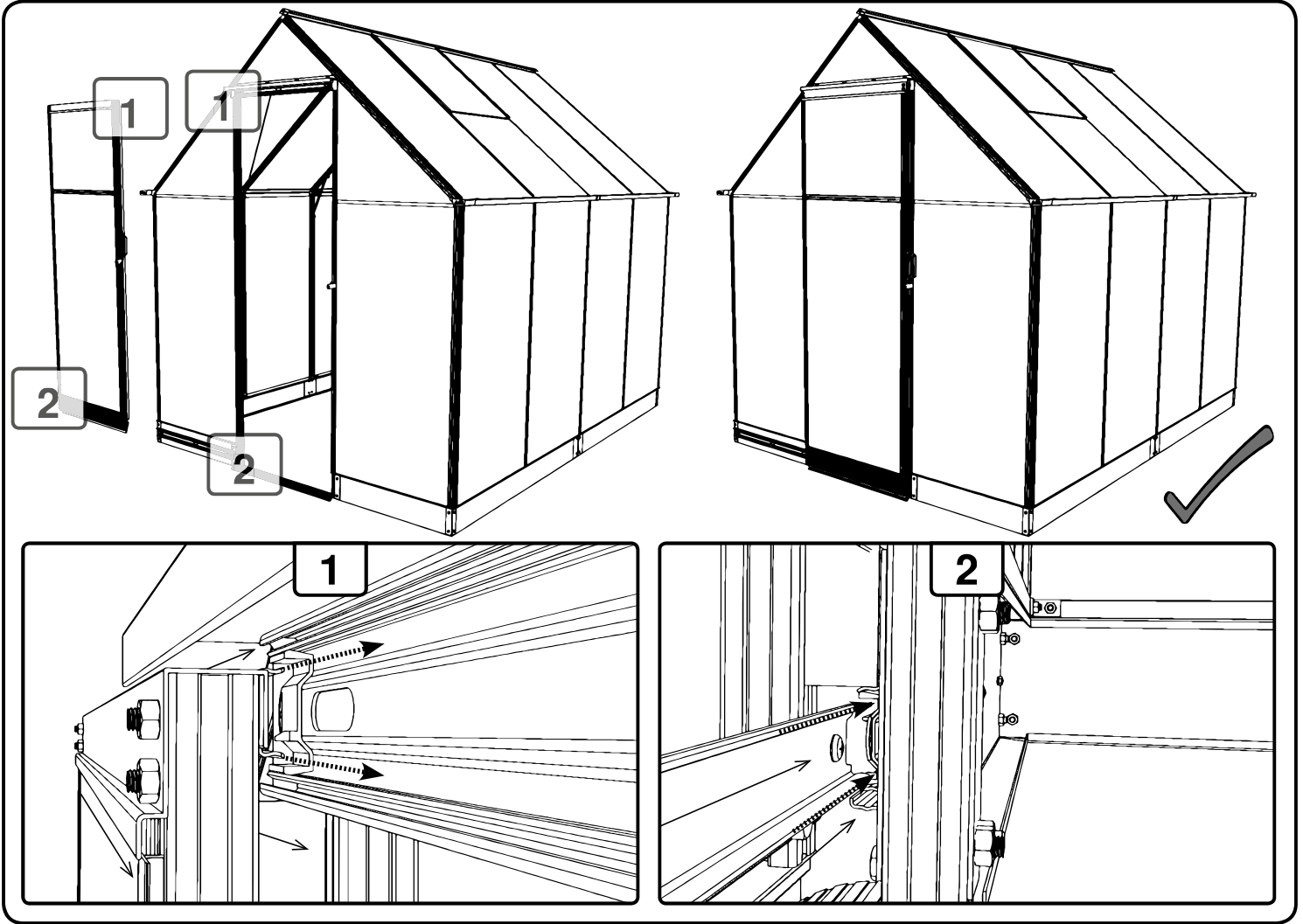

20-1008

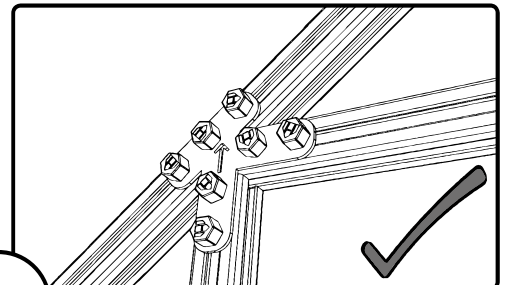
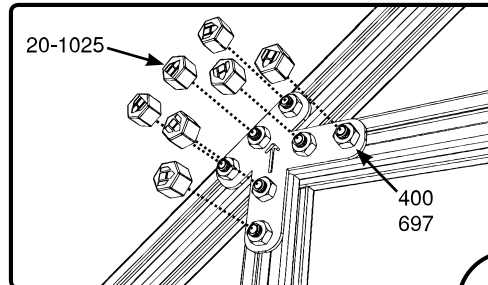
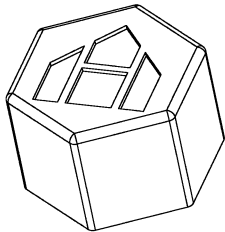
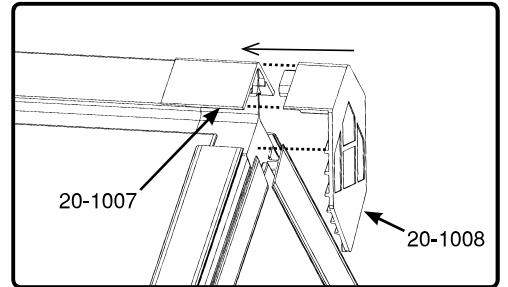
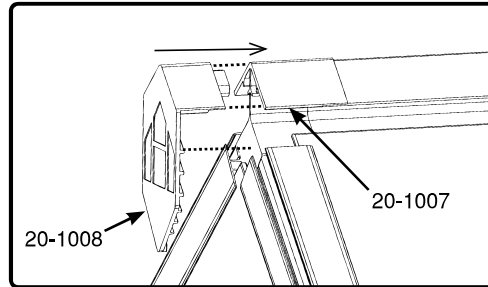

e.g.

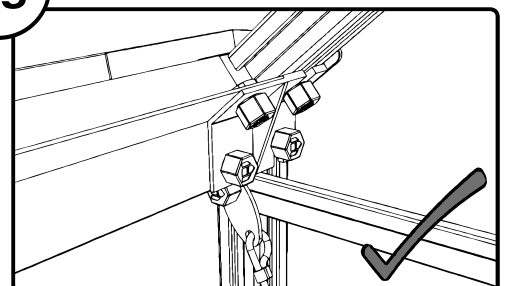
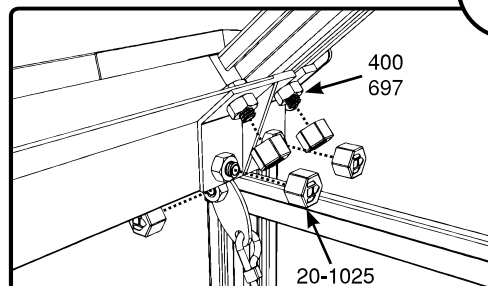

20-1025	
66 (3,9 m ²)	133
68 (5,1 m ²)	171
610 (6,4 m ²)	177



DENMARK: Juliana Drivhuse
A/S Sivlandvænget 29, DK -
5260
Odense, Denmark
+ 45 66 11 18 11

UK:
Juliana Group Ltd
The Distribution Centre Stoke Road,
Cheltenham, GL52 7RS
+ 44 (0) 1242 676625

GERMANY:
Juliana Gewächshäuser GmbH
Hammer Deich 70
20537 Hamburg, Germany
+49 (0) 1805 136 143

EESTI: Anu Poed OÜ
Tallinn Tartu
+372 501 409
www.kasvuhooned.ee,
www.juliana.ee

www.hallsgreenhouses.com

